

KEYING OPTION, SCALE: 2:1

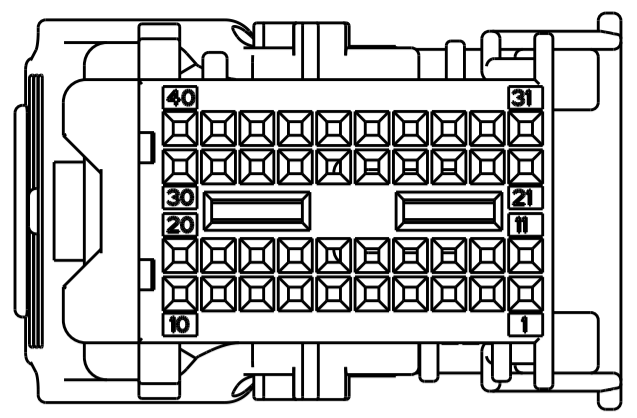

ASSY P/N: 2098633-1
KEYING: A

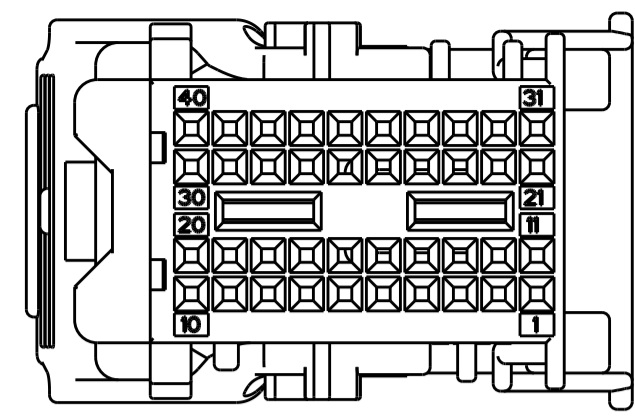

ASSY P/N: 2098633-2
KEYING: B

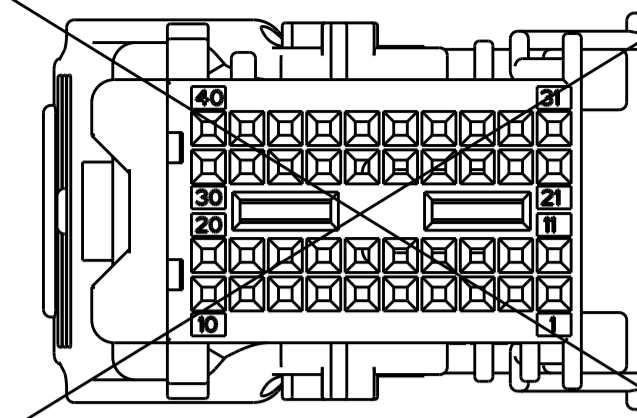

ASSY P/N: 2098633-3
KEYING: C

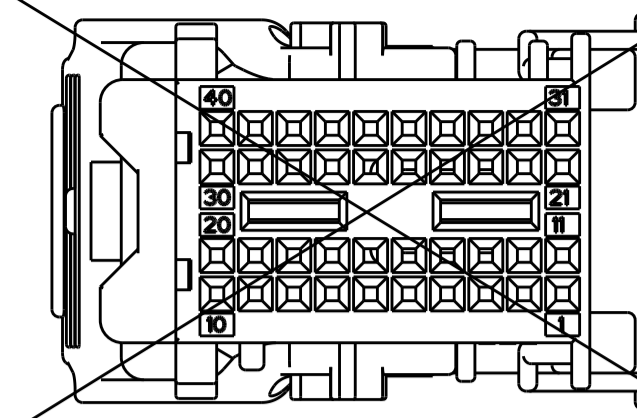

ASSY P/N: 2098633-4
KEYING: D

| REVISIONS | | | | | |
|-----------|------|---------------------------|-----------|------|-------|
| P. | LTN. | DESCRIPTION | DATE | DMN. | APVD. |
| A | | REVISED PER ECR-12-010595 | 11JUN2012 | MBH | RH |
| B | | REVISED PER ECO-15-011566 | 15SEP2015 | DLD | CJS |
| B1 | | REVISED PER ECO-18-014182 | 11SEP2018 | JMS | CS |

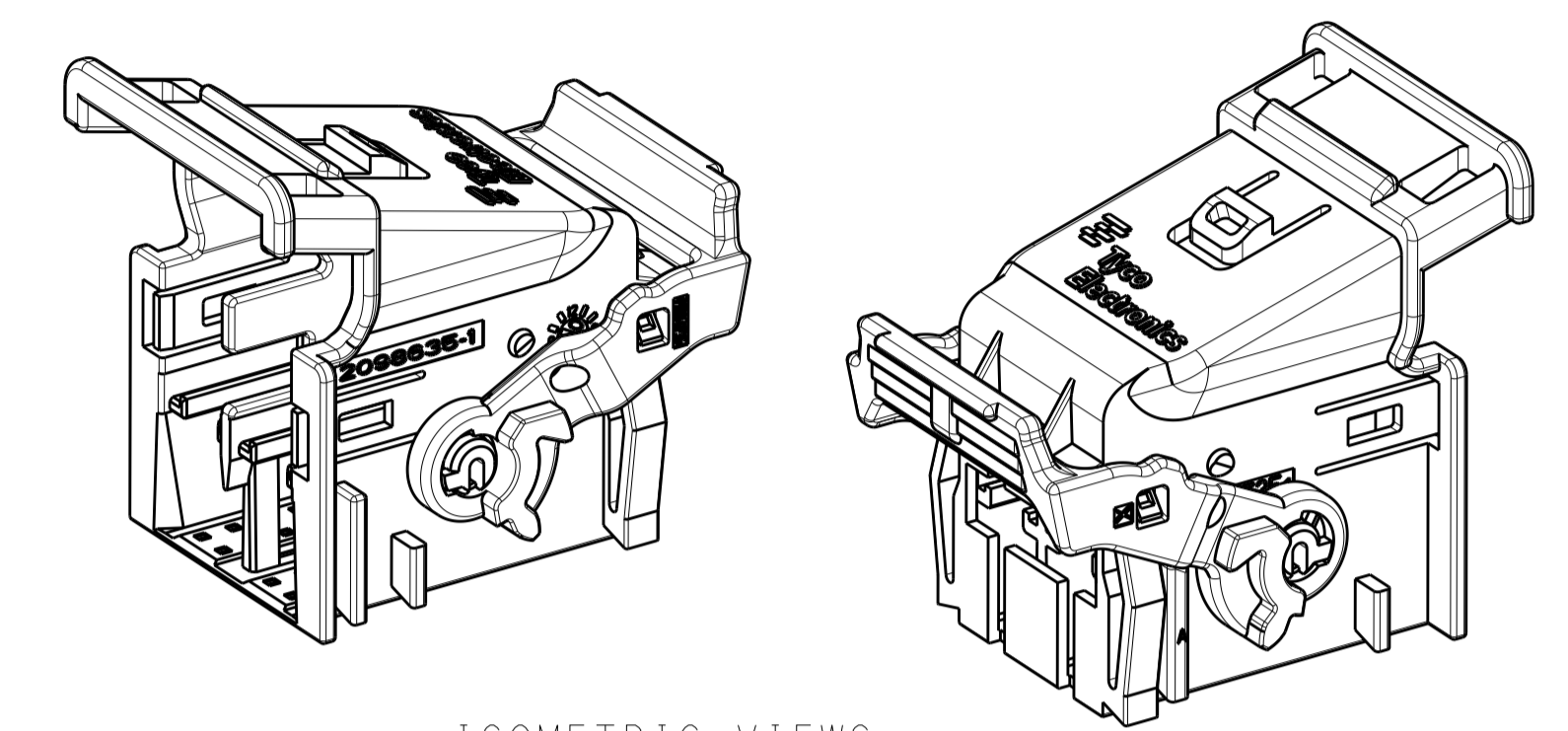
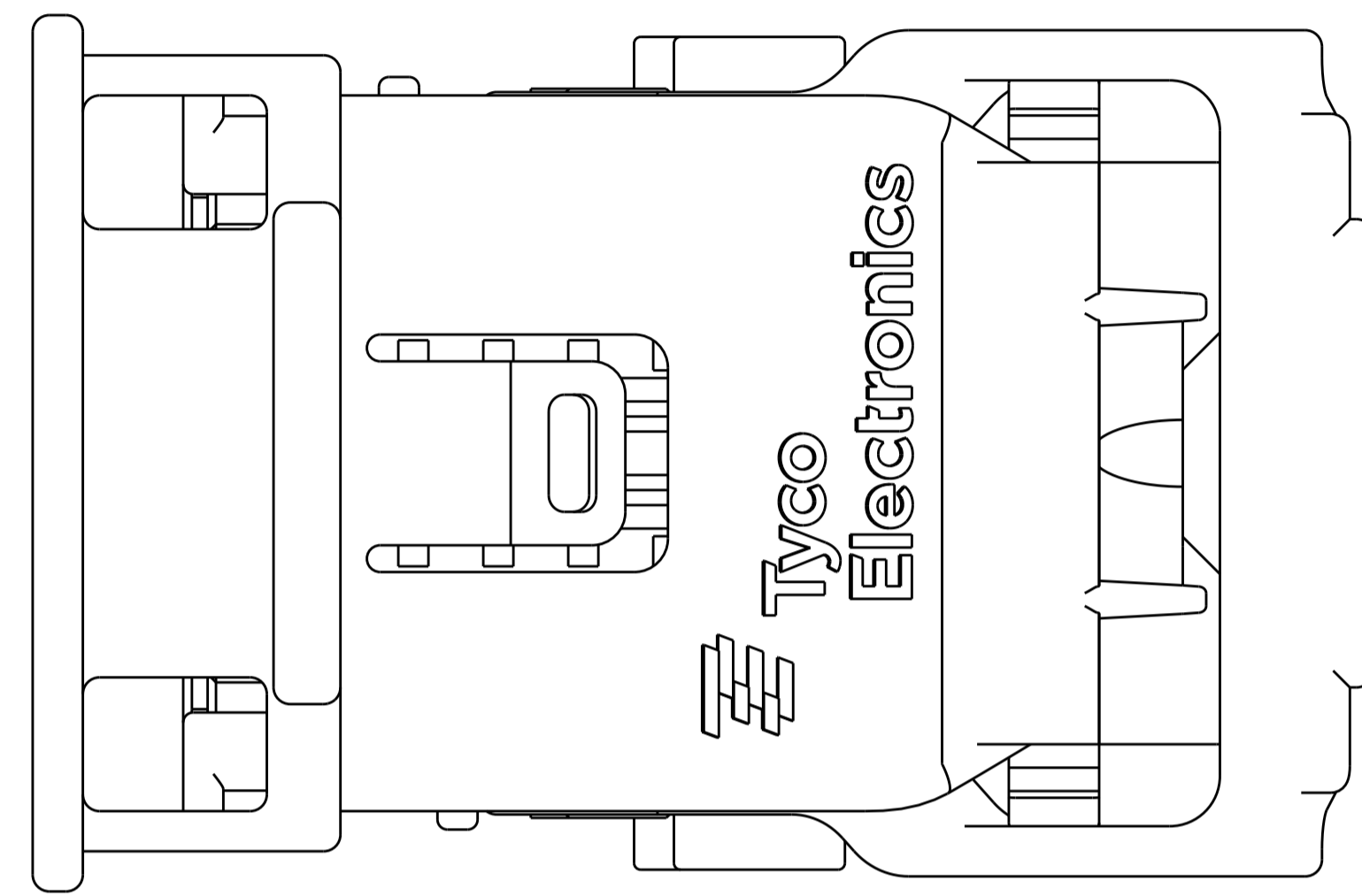

ISOMETRIC VIEWS
SCALE 2:1

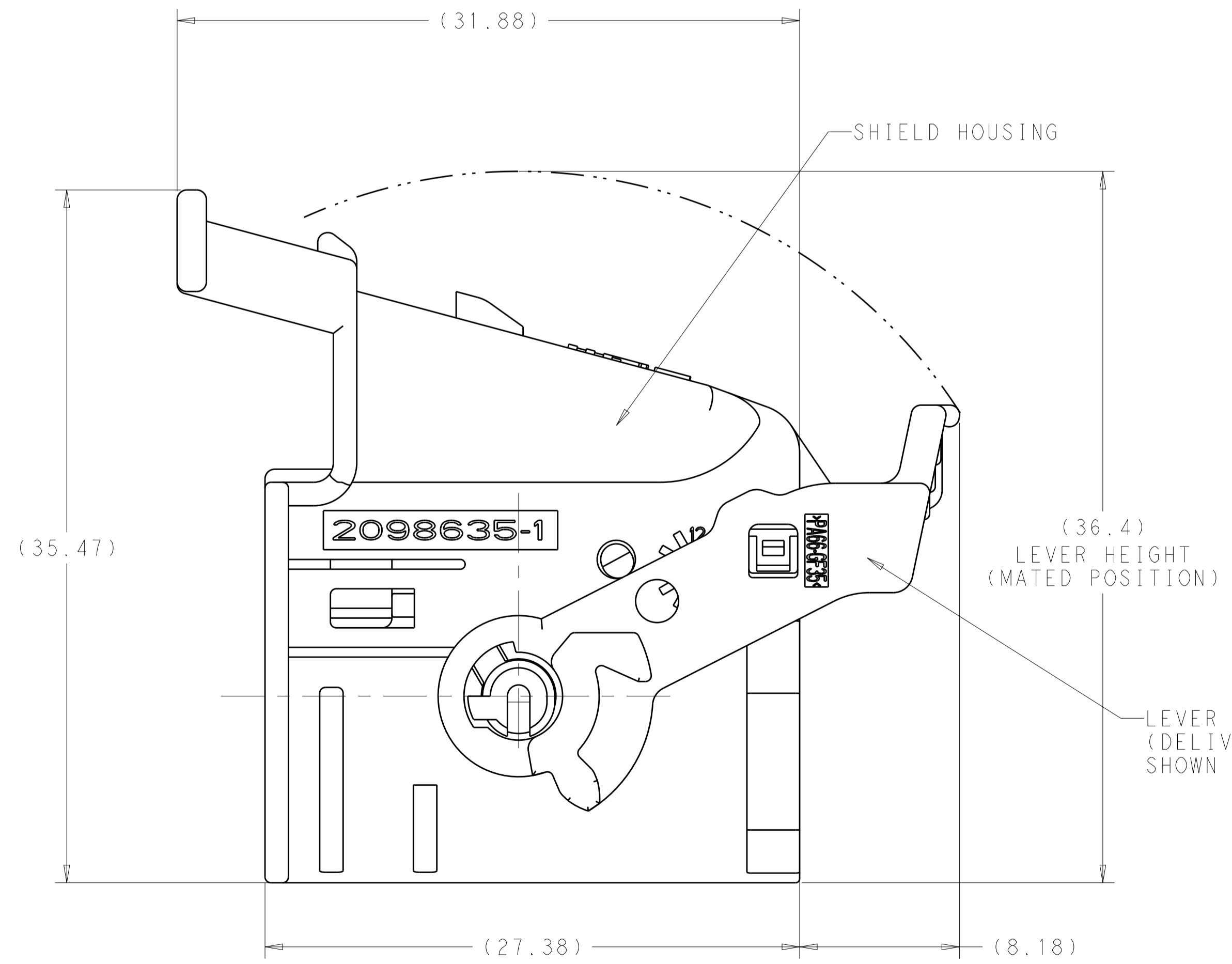
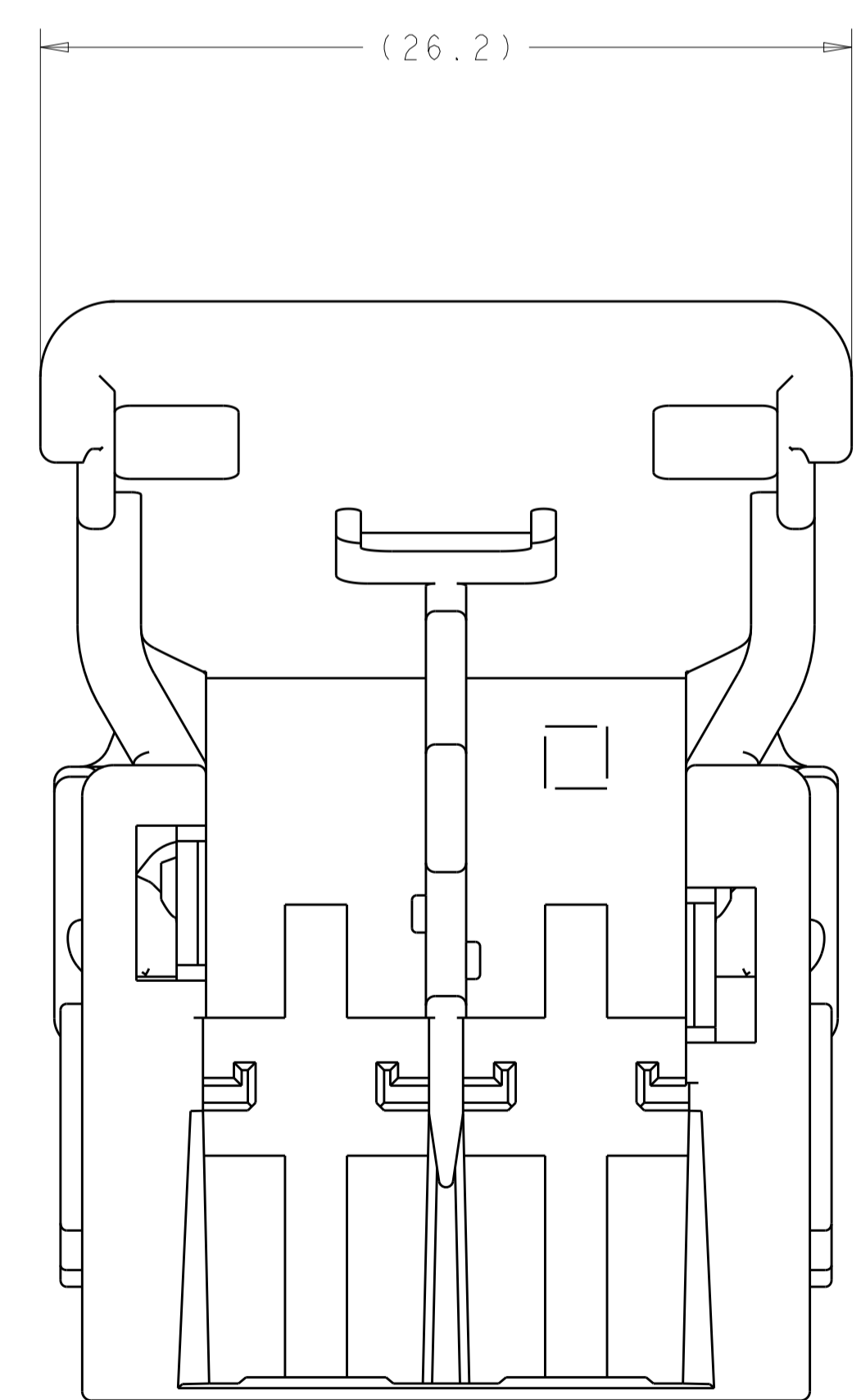

- ▲ MATERIAL: SHIELD - 35% GLASS REINFORCED NYLON.
SEE TABLE BELOW FOR COLOR.
LEVER - 35% GLASS REINFORCED NYLON.
COLOR: DARK GRAY.
- 2. REFERENCE: CARRIER 2098634-1 AND 2098634-2
USED WITH THIS ASSEMBLY.
- 3. REFERENCE: INTERFACE DETAIL PER TE DRAWING NO 2098633-MXCU.

| | | |
|-------|-------------|-------------|
| BLACK | D | 2098633-4 |
| BLUE | C | 2098633-3 |
| GRAY | B | 2098633-2 |
| BLACK | A | 2098633-1 |
| COLOR | KEYING OPT. | PART NUMBER |

| | | | |
|--|--|--------------------------|---|
| THIS DRAWING IS A CONTROLLED DOCUMENT. | | DMN: S. VINAY 22MAR2010 | |
| DIMENSIONS: mm | | CHK: M. GALEN 22MAR2010 | |
| TOLERANCES UNLESS OTHERWISE SPECIFIED: | | APVD: M. GALEN 22MAR2010 | NAME: SHIELD ASSEMBLY, 40 POSITION GENERATION Y LAC |
| 0 PLC ± | | PRODUCT SPEC | SIZE: A1 |
| 1 PLC ± | | APPLICATION SPEC | CAGE CODE: 00779 |
| 2 PLC ± | | WEIGHT | REV: B1 |
| 3 PLC ± | | CUSTOMER DRAWING | SCALE: 5:1 |
| 4 PLC ± | | | SHEET 1 OF 1 |
| ANGLES ±1° | | | |
| FINISH | | | |

Mouser Electronics

Authorized Distributor

Click to View Pricing, Inventory, Delivery & Lifecycle Information:

[TE Connectivity:](#)

[2098633-1](#)