

MAX3483E/MAX3485E/ MAX3486E/MAX3488E/ MAX3490E/MAX3491E

3.3V-Powered, ±15kV ESD-Protected, 12Mbps and Slew-Rate-Limited True RS-485/RS-422 Transceivers

General Description

Devices in the MAX3483E family (MAX3483E/MAX3485E/MAX3486E/MAX3488E/MAX3490E/MAX3491E) are ±15kV ESD-protected, +3.3V, low-power transceivers for RS-485 and RS-422 communications. Each device contains one driver and one receiver. The MAX3483E and MAX3488E feature slew-rate-limited drivers that minimize EMI and reduce reflections caused by improperly terminated cables, allowing error-free data transmission at data rates up to 250kbps. The partially slew-rate-limited MAX3486E transmits up to 2.5Mbps. The MAX3485E, MAX3490E, and MAX3491E transmit at up to 12Mbps.

All devices feature enhanced electrostatic discharge (ESD) protection. All transmitter outputs and receiver inputs are protected to ±15kV using IEC 1000-4-2 Air-Gap Discharge, ±8kV using IEC 1000-4-2 Contact Discharge, and ±15kV using the Human Body Model.

Drivers are short-circuit current limited and are protected against excessive power dissipation by thermal shutdown circuitry that places the driver outputs into a high-impedance state. The receiver input has a fail-safe feature that guarantees a logic-high output if both inputs are open circuit.

The MAX3488E, MAX3490E, and MAX3491E feature full-duplex communication, while the MAX3483E, MAX3485E, and MAX3486E are designed for half-duplex communication.

Applications

- Telecommunications
- Industrial-Control Local Area Networks
- Transceivers for EMI-Sensitive Applications
- Integrated Services Digital Networks
- Packet Switching

Selector Guide

PART NUMBER	GUARANTEED DATA RATE (Mbps)	SUPPLY VOLTAGE (V)	HALF/FULL DUPLEX	SLEW-RATE LIMITED	DRIVER/RECEIVER ENABLE	SHUTDOWN CURRENT (nA)	±15kV ESD PROTECTION	PIN COUNT
MAX3483E	0.25	3.0 to 3.6	Half	Yes	Yes	2	Yes	8
MAX3485E	12		Half	No	Yes	2	Yes	8
MAX3486E	2.5		Half	Yes	Yes	2	Yes	8
MAX3488E	0.25		Full	Yes	No	—	Yes	8
MAX3490E	12		Full	No	No	—	Yes	8
MAX3491E	12		Full	No	Yes	2	Yes	14

Features

- ESD Protection for RS-485 I/O Pins
 - ±15kV—Human Body Model
 - ±8kV—IEC 1000-4-2, Contact Discharge
 - ±15kV—IEC 1000-4-2, Air-Gap Discharge
- Operate from a Single +3.3V Supply—No Charge Pump Required
- Interoperable with +5V Logic
- Guaranteed 12Mbps Data Rate (MAX3485E/MAX3490E/MAX3491E)
- Slew-Rate Limited for Errorless Data Transmission (MAX3483E/MAX3488E)
- 2nA Low-Current Shutdown Mode (MAX3483E/MAX3485E/MAX3486E/MAX3491E)
- -7V to +12V Common-Mode Input Voltage Range
- Full-Duplex and Half-Duplex Versions Available
- Industry-Standard 75176 Pinout (MAX3483E/MAX3485E/MAX3486E)
- Current-Limiting and Thermal Shutdown for Driver Overload Protection

Ordering Information

PART	TEMP. RANGE	PIN-PACKAGE
MAX3483ECSA	0°C to+70°C	8 SO
MAX3483ECPA	0°C to+70°C	8 Plastic DIP
MAX3483EESA	-40°C to+85°C	8 SO
MAX3483EEPA	-40°C to+85°C	8 Plastic DIP

Ordering Information continued at end of data sheet.

MAX3483E/MAX3485E/
 MAX3486E/MAX3488E/
 MAX3490E/MAX3491E

3.3V-Powered, ±15kV ESD-Protected,
 12Mbps and Slew-Rate-Limited
 True RS-485/RS-422 Transceivers

Absolute Maximum Ratings

Supply Voltage (V _{CC}).....+7V	14-Pin SO (derate 8.33mW/°C above +70°C)667mW
Control Input Voltage (RE, DE).....-0.3V to +7V	14-Pin Plastic DIP (derate 10mW/°C above +70°C).....800mW
Driver Input Voltage (DI).....-0.3V to +7V	Operating Temperature Ranges
Driver Output Voltage (A, B, Y, Z).....-7.5V to +12.5V	MAX34__EC__.....0°C to +70°C
Receiver Input Voltage (A, B).....-7.5V to +12.5V	MAX34__EE__.....-40°C to +85°C
Receiver Output Voltage (RO).....-0.3V to (V _{CC} + 0.3V)	Junction Temperature.....+150°C
Continuous Power Dissipation (T _A = +70°C)	Storage Temperature Range.....-65°C to +150°C
8-Pin SO (derate 5.88mW/°C above +70°C).....471mW	Lead Temperature (soldering, 10sec).....+300°C
8-Pin Plastic DIP (derate 9.09mW/°C above +70°C).....727mW	

Stresses beyond those listed under "Absolute Maximum Ratings" may cause permanent damage to the device. These are stress ratings only, and functional operation of the device at these or any other conditions beyond those indicated in the operational sections of the specifications is not implied. Exposure to absolute maximum rating conditions for extended periods may affect device reliability.

Package Information

TDFN-14

PACKAGE CODE	S14+1
Outline Number	21-0041
Land Pattern Number	90-0112
Thermal Resistance, Single-Layer Board:	
Junction to Ambient (θ _{JA})	120°C/W
Junction to Case (θ _{JC})	37°C/W
Thermal Resistance, Four-Layer Board:	
Junction to Ambient (θ _{JA})	84°C/W
Junction to Case (θ _{JC})	34°C/W

For the latest package outline information and land patterns (footprints), go to www.maximintegrated.com/packages. Note that a "+", "#", or "-" in the package code indicates RoHS status only. Package drawings may show a different suffix character, but the drawing pertains to the package regardless of RoHS status.

Package thermal resistances were obtained using the method described in JEDEC specification JESD51-7, using a four-layer board. For detailed information on package thermal considerations, refer to www.maximintegrated.com/thermal-tutorial.

MAX3483E/MAX3485E/
MAX3486E/MAX3488E/
MAX3490E/MAX3491E

3.3V-Powered, $\pm 15\text{kV}$ ESD-Protected,
12Mbps and Slew-Rate-Limited
True RS-485/RS-422 Transceivers

DC Electrical Characteristics

($V_{CC} = +3.3\text{V} \pm 0.3\text{V}$, $T_A = T_{MIN}$ to T_{MAX} , unless otherwise noted. Typical values are at $T_A = +25^\circ\text{C}$.)

PARAMETER	SYMBOL	CONDITIONS	MIN	TYP	MAX	UNITS
Differential Driver Output	V_{OD}	$R_L = 100\Omega$ (RS-422), Figure 4	2.0			V
		$R_L = 54\Omega$ (RS-485), Figure 4	1.5			
		$R_L = 60\Omega$ (RS-485), $V_{CC} = 3.3\text{V}$, Figure 5	1.5			
Change in Magnitude of Driver Differential Output Voltage for Complementary Output States (Note 1)	ΔV_{OD}	$R_L = 54\Omega$ or 100Ω , Figure 4			0.2	V
Driver Common-Mode Output Voltage	V_{OC}	$R_L = 54\Omega$ or 100Ω , Figure 4			3	V
Change in Magnitude of Common-Mode Output Voltage (Note 1)	ΔV_{OC}	$R_L = 54\Omega$ or 100Ω , Figure 4			0.2	V
Input High Voltage	V_{IH}	DE, DI, \overline{RE}	2.0			V
Input Low Voltage	V_{IL}	DE, DI, \overline{RE}			0.8	V
Logic Input Current	I_{IN1}	DE, DI, \overline{RE}			± 2	μA
Input Current (A, B)	I_{IN2}	DE = 0V, $V_{CC} = 0\text{V}$ or 3.6V	$V_{IN} = 12\text{V}$		1.0	mA
			$V_{IN} = -7\text{V}$		-0.8	
Output Leakage (Y, Z)	I_O	DE = 0V, $\overline{RE} = 0\text{V}$, $V_{CC} = 0\text{V}$ or 3.6V , MAX3491E	$V_{OUT} = 12\text{V}$		20	μA
			$V_{OUT} = -7\text{V}$		-20	
Output Leakage (Y, Z) in Shutdown Mode	I_O	DE = 0V, $\overline{RE} = V_{CC}$, $V_{CC} = 0\text{V}$ or 3.6V , MAX3491E	$V_{OUT} = 12\text{V}$		1	μA
			$V_{OUT} = -7\text{V}$		-1	
Receiver Differential Threshold Voltage	V_{TH}	$-7\text{V} \leq V_{CM} \leq 12\text{V}$	-0.2		0.2	V
Receiver Input Hysteresis	ΔV_{TH}	$V_{CM} = 0\text{V}$		50		mV
Receiver Output High Voltage	V_{OH}	$I_{OUT} = -1.5\text{mA}$, $V_{ID} = 200\text{mV}$, Figure 6	$V_{CC} - 0.4$			V
Receiver Output Low Voltage	V_{OL}	$I_{OUT} = 2.5\text{mA}$, $V_{ID} = 200\text{mV}$, Figure 6			0.4	V
Three-State (High Impedance) Output Current at Receiver	I_{OZR}	$V_{CC} = 3.6\text{V}$, $0\text{V} \leq V_{OUT} \leq V_{CC}$			± 1	μA
Receiver Input Resistance	R_{IN}	$-7\text{V} \leq V_{CM} \leq 12\text{V}$	12			k Ω
Supply Voltage Range	V_{CC}		3.0		3.6	V

MAX3483E/MAX3485E/
MAX3486E/MAX3488E/
MAX3490E/MAX3491E

3.3V-Powered, ±15kV ESD-Protected,
12Mbps and Slew-Rate-Limited
True RS-485/RS-422 Transceivers

DC Electrical Characteristics (continued)

($V_{CC} = +3.3V \pm 0.3V$, $T_A = T_{MIN}$ to T_{MAX} , unless otherwise noted. Typical values are at $T_A = +25^\circ C$)

PARAMETER	SYMBOL	CONDITIONS	MIN	TYP	MAX	UNITS	
Supply Current	I_{CC}	No load, DI = 0 or V_{CC}	DE = V_{CC} , $\overline{RE} = 0$ or V_{CC}		1.1	2.2	mA
			DE = 0V, $\overline{RE} = 0$		0.95	1.9	
Supply Current in Shutdown Mode	I_{SHDN}	DE = 0, $\overline{RE} = V_{CC}$, DI = V_{CC} or 0			0.002	1	μA
Driver Short-Circuit Output Current	I_{OSD}	$V_{OUT} = -7V$				-250	mA
		$V_{OUT} = 12V$				250	
Receiver Short-Circuit Output Current	I_{OSR}	$0 \leq V_{RO} \leq V_{CC}$			±8	±60	mA
ESD Protection for Y, Z, A, B		IEC 1000-4-2 Air Discharge			±15		kV
		IEC 1000-4-2 Contact Discharge (MAX3483E, MAX3485E, MAX3486E, MAX3491E)			±8		
		IEC 1000-4-2 Contact Discharge (MAX3490E, MAX3488E)*			±6		
		Human Body Model			±15		

*MAX3488E and MAX3491E will be compliant to ±8kV per IEC 1000-4-2 Contact Discharge by September 1999.

Driver Switching Characteristics—MAX3485E/MAX3490E/MAX3491E

($V_{CC} = +3.3V$, $T_A = +25^\circ C$.)

PARAMETER	SYMBOL	CONDITIONS	MIN	TYP	MAX	UNITS
Maximum Data Rate			12	15		Mbps
Driver Differential Output Delay	t_{DD}	$R_L = 60\Omega$, Figure 7	1	22	35	ns
Driver Differential Output Transition Time	t_{TD}	$R_L = 60\Omega$, Figure 7	3	11	25	ns
Driver Propagation Delay, Low-to-High Level	t_{PLH}	$R_L = 27\Omega$, Figure 8	7	23	35	ns
Driver Propagation Delay, High-to-Low Level	t_{PHL}	$R_L = 27\Omega$, Figure 8	7	23	35	ns
$ t_{PLH} - t_{PHL} $ Driver Propagation Delay Skew (Note 2)	t_{PDS}	$R_L = 27\Omega$, Figure 8		-1.4	±8	ns
DRIVER-OUTPUT ENABLE/DISABLE TIMES (MAX3485E/MAX3491E only)						
Driver-Output Enable Time to Low Level	t_{PZL}	$R_L = 110\Omega$, Figure 10		42	90	ns
Driver-Output Enable Time to High Level	t_{PZH}	$R_L = 110\Omega$, Figure 9		42	90	ns
Driver-Output Disable Time from High Level	t_{PHZ}	$R_L = 110\Omega$, Figure 9		35	80	ns
Driver-Output Disable Time from Low Level	t_{PLZ}	$R_L = 110\Omega$, Figure 10		35	80	ns
Driver-Output Enable Time from Shutdown to Low Level	t_{PSL}	$R_L = 110\Omega$, Figure 10		650	900	ns
Driver-Output Enable Time from Shutdown to High Level	t_{PSH}	$R_L = 110\Omega$, Figure 9		650	900	ns

MAX3483E/MAX3485E/
MAX3486E/MAX3488E/
MAX3490E/MAX3491E

3.3V-Powered, ±15kV ESD-Protected,
12Mbps and Slew-Rate-Limited
True RS-485/RS-422 Transceivers

Driver Switching Characteristics—MAX3486E

($V_{CC} = +3.3V$, $T_A = +25^{\circ}C$.)

PARAMETER	SYMBOL	CONDITIONS	MIN	TYP	MAX	UNITS
Maximum Data Rate			2.5			Mbps
Driver Differential Output Delay	t_{DD}	$R_L = 60\Omega$, Figure 7	20	42	70	ns
Driver Differential Output Transition Time	t_{TD}	$R_L = 60\Omega$, Figure 7	15	28	60	ns
Driver Propagation Delay, Low-to-High Level	t_{PLH}	$R_L = 27\Omega$, Figure 8	20	42	75	ns
Driver Propagation Delay, High-to-Low Level	t_{PHL}	$R_L = 27\Omega$, Figure 8	20	42	75	ns
$ t_{PLH} - t_{PHL} $ Driver Propagation Delay Skew (Note 2)	t_{PDS}	$R_L = 27\Omega$, Figure 8		-6	±12	ns
DRIVER-OUTPUT ENABLE/DISABLE TIMES						
Driver Output Enable Time to Low Level	t_{PZL}	$R_L = 110\Omega$, Figure 10		52	100	ns
Driver Output Enable Time to High Level	t_{PZH}	$R_L = 110\Omega$, Figure 9		52	100	ns
Driver Output Disable Time from High Level	t_{PHZ}	$R_L = 110\Omega$, Figure 9		40	80	ns
Driver Output Disable Time from Low Level	t_{PLZ}	$R_L = 110\Omega$, Figure 10		40	80	ns
Driver Output Enable Time from Shutdown to Low Level	t_{PSL}	$R_L = 110\Omega$, Figure 10		700	1000	ns
Driver Output Enable Time from Shutdown to High Level	t_{PSH}	$R_L = 110\Omega$, Figure 9		700	1000	ns

Driver Switching Characteristics—MAX3483E/MAX3488E

($V_{CC} = +3.3V$, $T_A = +25^{\circ}C$.)

PARAMETER	SYMBOL	CONDITIONS	MIN	TYP	MAX	UNITS
Maximum Data Rate			250			kbps
Driver Differential Output Delay	t_{DD}	$R_L = 60\Omega$, Figure 7	600	900	1400	ns
Driver Differential Output Transition Time	t_{TD}	$R_L = 60\Omega$, Figure 7	400	740	1200	ns
Driver Propagation Delay, Low-to-High Level	t_{PLH}	$R_L = 27\Omega$, Figure 8	700	930	1500	ns
Driver Propagation Delay, High-to-Low Level	t_{PHL}	$R_L = 27\Omega$, Figure 8	700	930	1500	ns
$ t_{PLH} - t_{PHL} $ Driver Propagation Delay Skew (Note 2)	t_{PDS}	$R_L = 27\Omega$, Figure 8		±50		ns
DRIVER-OUTPUT ENABLE/DISABLE TIMES (MAX3483E only)						
Driver-Output Enable Time to Low Level	t_{PZL}	$R_L = 110\Omega$, Figure 10		900	1300	ns
Driver-Output Enable Time to High Level	t_{PZH}	$R_L = 110\Omega$, Figure 9		600	800	ns
Driver-Output Disable Time from High Level	t_{PHZ}	$R_L = 110\Omega$, Figure 9		50	80	ns
Driver-Output Disable Time from Low Level	t_{PLZ}	$R_L = 110\Omega$, Figure 10		50	80	ns
Driver-Output Enable Time from Shutdown to Low Level	t_{PSL}	$R_L = 110\Omega$, Figure 10		1.9	2.7	μs
Driver-Output Enable Time from Shutdown to High Level	t_{PSH}	$R_L = 110\Omega$, Figure 9		2.2	3.0	μs

MAX3483E/MAX3485E/
MAX3486E/MAX3488E/
MAX3490E/MAX3491E

3.3V-Powered, ±15kV ESD-Protected,
12Mbps and Slew-Rate-Limited
True RS-485/RS-422 Transceivers

Receiver Switching Characteristics

($V_{CC} = +3.3V$, $T_A = +25^\circ C$)

PARAMETER	SYMBOL	CONDITIONS	MIN	TYP	MAX	UNITS
Time to Shutdown	t_{SHDN}	MAX3483E/MAX3485E/MAX3486E/MAX3491E only (Note 3)	80	190	300	ns
Receiver Propagation Delay, Low-to-High Level	t_{RPLH}	$V_{ID} = 0$ to 3.0, $C_L = 15pF$, Figure 11	25	62	90	ns
		MAX3483E/MAX3488E	25	75	120	
Receiver Propagation Delay, High-to-Low Level	t_{RPHL}	$V_{ID} = 0$ to 3.0, $C_L = 15pF$, Figure 11	25	62	90	ns
		MAX3483E/MAX3488E	25	75	120	
$t_{PLH} - t_{PHL}$ Receiver Propagation Delay Skew	t_{RPDS}	$V_{ID} = 0$ to 3.0, $C_L = 15pF$, Figure 11		6	±10	ns
		MAX3483E/MAX3488E		12	±20	
Receiver Output Enable Time to Low Level	t_{PRZL}	$C_L = 15pF$, Figure 12, MAX3483E/85E/86E/91E only		25	50	ns
Receiver Output Enable Time to High Level	t_{PRZH}	$C_L = 15pF$, Figure 12, MAX3483E/85E/86E/91E only		25	50	ns
Receiver Output Disable Time from High Level	t_{PRHZ}	$C_L = 15pF$, Figure 12, MAX3483E/85E/86E/91E only		25	45	ns
Receiver Output Disable Time from Low Level	t_{PRLZ}	$C_L = 15pF$, Figure 12, MAX3483E/85E/86E/91E only		25	45	ns
Receiver Output Enable Time from Shutdown to Low Level	t_{PRSL}	$C_L = 15pF$, Figure 12, MAX3483E/85E/86E/91E only		720	1400	ns
Receiver Output Enable Time from Shutdown to High Level	t_{PRSH}	$C_L = 15pF$, Figure 12, MAX3483E/85E/86E/91E only		720	1400	ns

Note 1: ΔV_{OD} and ΔV_{OC} are the changes in V_{OD} and V_{OC} , respectively, when the DI input changes state.

Note 2: Measured on $|t_{PLH}(Y) - t_{PHL}(Y)|$ and $|t_{PLH}(Z) - t_{PHL}(Z)|$.

Note 3: The transceivers are put into shutdown by bringing \overline{RE} high and DE low. If the inputs are in this state for less than 80ns, the parts are guaranteed not to enter shutdown. If the inputs are in this state for at least 300ns, the parts are guaranteed to have entered shutdown. See *Low-Power Shutdown Mode* section.

MAX3483E/MAX3485E/
 MAX3486E/MAX3488E/
 MAX3490E/MAX3491E

3.3V-Powered, $\pm 15\text{kV}$ ESD-Protected,
 12Mbps and Slew-Rate-Limited
 True RS-485/RS-422 Transceivers

Typical Operating Characteristics

($V_{CC} = +3.3\text{V}$, $T_A = +25^\circ\text{C}$, unless otherwise noted.)

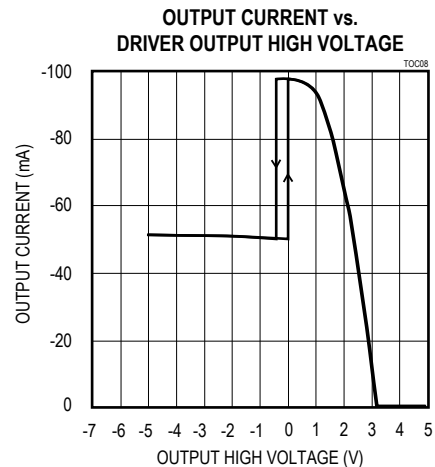
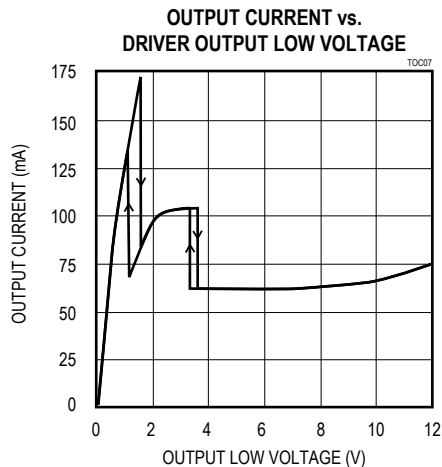
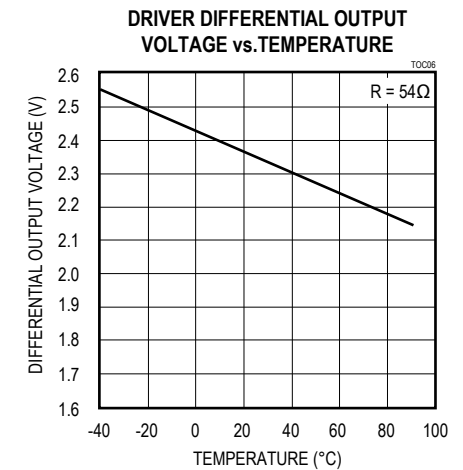
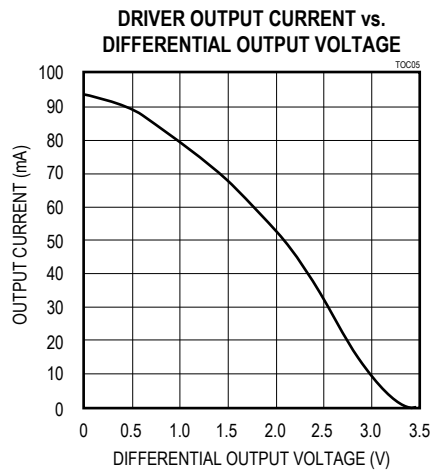
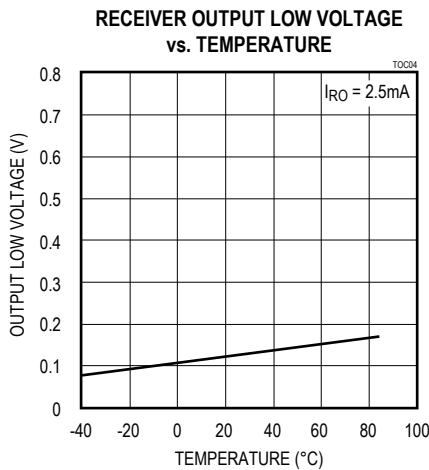
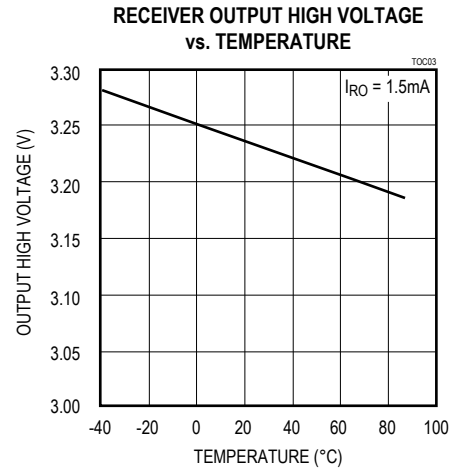
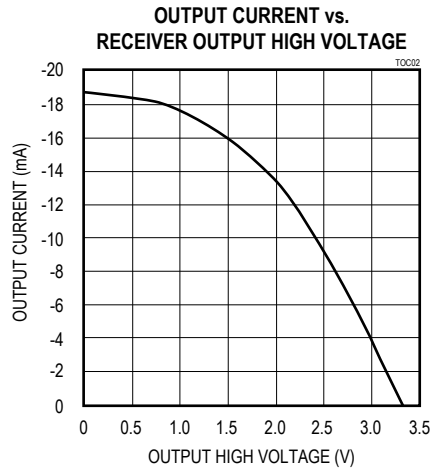
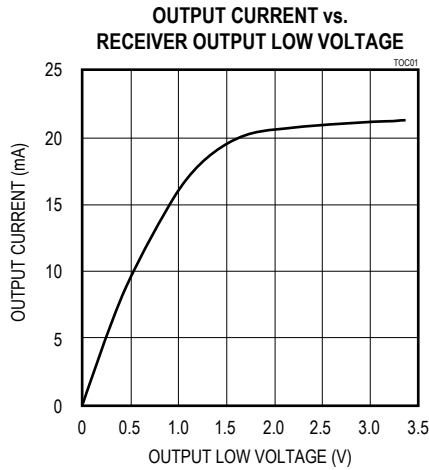

MAX3483E/MAX3485E/
MAX3486E/MAX3488E/
MAX3490E/MAX3491E

3.3V-Powered, $\pm 15\text{kV}$ ESD-Protected,
12Mbps and Slew-Rate-Limited
True RS-485/RS-422 Transceivers

Typical Operating Characteristics (continued)

($V_{CC} = +3.3\text{V}$, $T_A = +25^\circ\text{C}$, unless otherwise noted.)

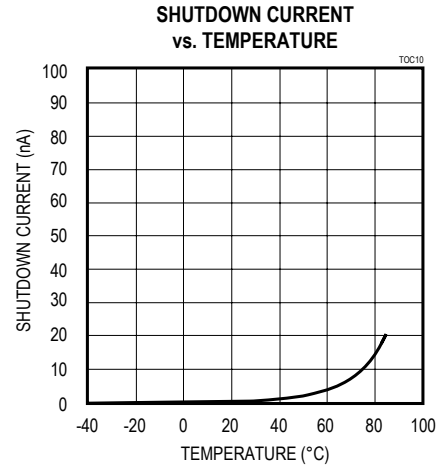
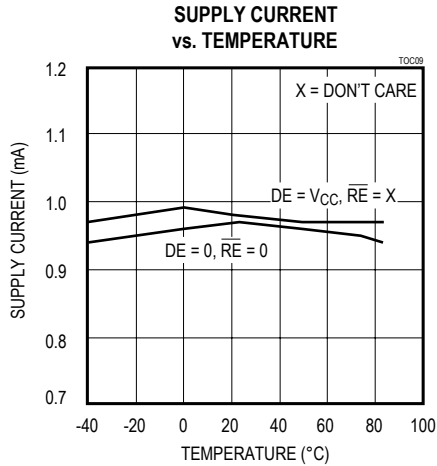

Pin Description

PIN			NAME	FUNCTION
MAX3483E MAX3485E MAX3486E	MAX3488E MAX3490E	MAX3491E		
1	2	2	RO	Receiver Output. If $A > B$ by 200mV, RO will be high; if $A < B$ by 200mV, RO will be low.
2	—	3	\overline{RE}	Receiver Output Enable. RO is enabled when \overline{RE} is low; RO is high impedance when \overline{RE} is high. If \overline{RE} is high and DE is low, the device will enter a low-power shutdown mode.
3	—	4	DE	Driver Output Enable. The driver outputs are enabled by bringing DE high. They are high impedance when DE is low. If \overline{RE} is high and DE is low, the device will enter a low-power shutdown mode. If the driver outputs are enabled, the parts function as line drivers. While they are high impedance, they function as line receivers if \overline{RE} is low.
4	3	5	DI	Driver Input. A low on DI forces output Y low and output Z high. Similarly, a high on DI forces output Y high and output Z low.
5	4	6, 7	GND	Ground
—	5	9	Y	Noninverting Driver Output
—	6	10	Z	Inverting Driver Output
6	—	—	A	Noninverting Receiver Input and Noninverting Driver Output
—	8	12	A	Noninverting Receiver Input
7	—	—	B	Inverting Receiver Input and Inverting Driver Output
—	7	11	B	Inverting Receiver Input
8	1	13, 14	V_{CC}	Positive Supply: $3.0\text{V} \leq V_{CC} \leq 3.6\text{V}$. Do not operate device with $V_{CC} > 3.6\text{V}$
—	—	1, 8	N.C.	No Connection. Not internally connected.

MAX3483E/MAX3485E/
MAX3486E/MAX3488E/
MAX3490E/MAX3491E

3.3V-Powered, ±15kV ESD-Protected,
12Mbps and Slew-Rate-Limited
True RS-485/RS-422 Transceivers

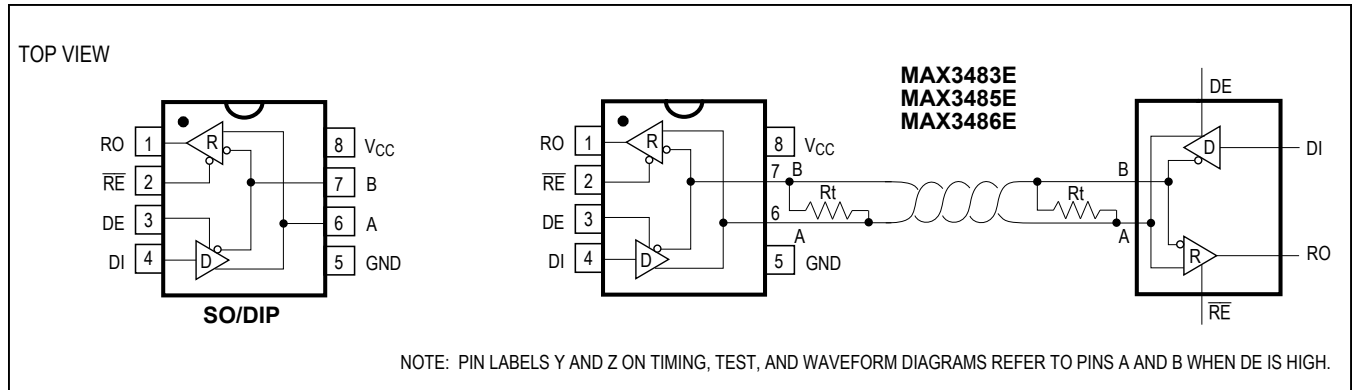

Figure 1. MAX3483E/MAX3485E/MAX3486E Pin Configuration and Typical Operating Circuit

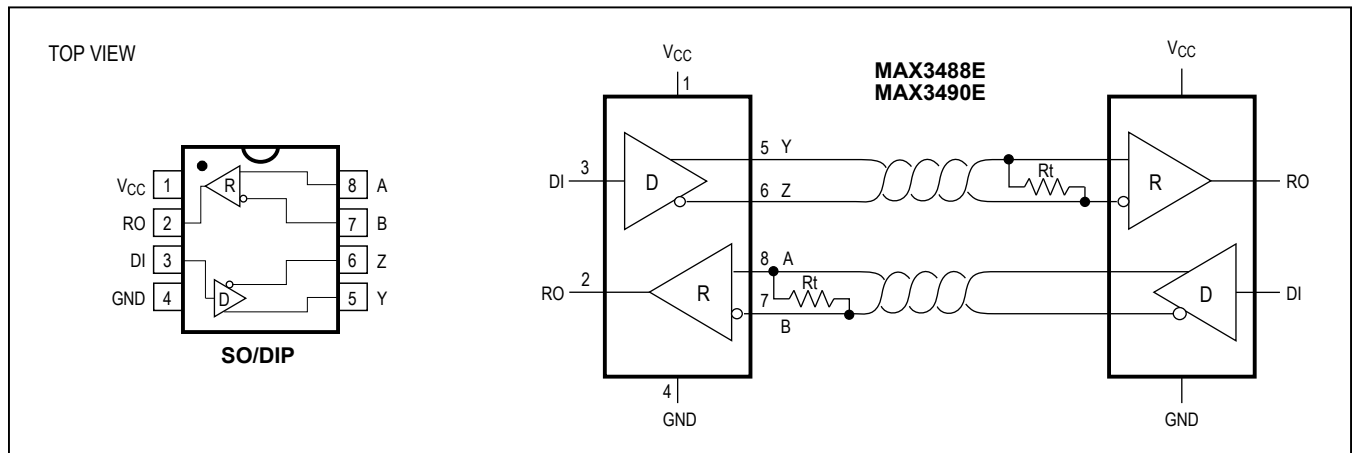

Figure 2. MAX3488E/MAX3490E Pin Configuration and Typical Operating Circuit

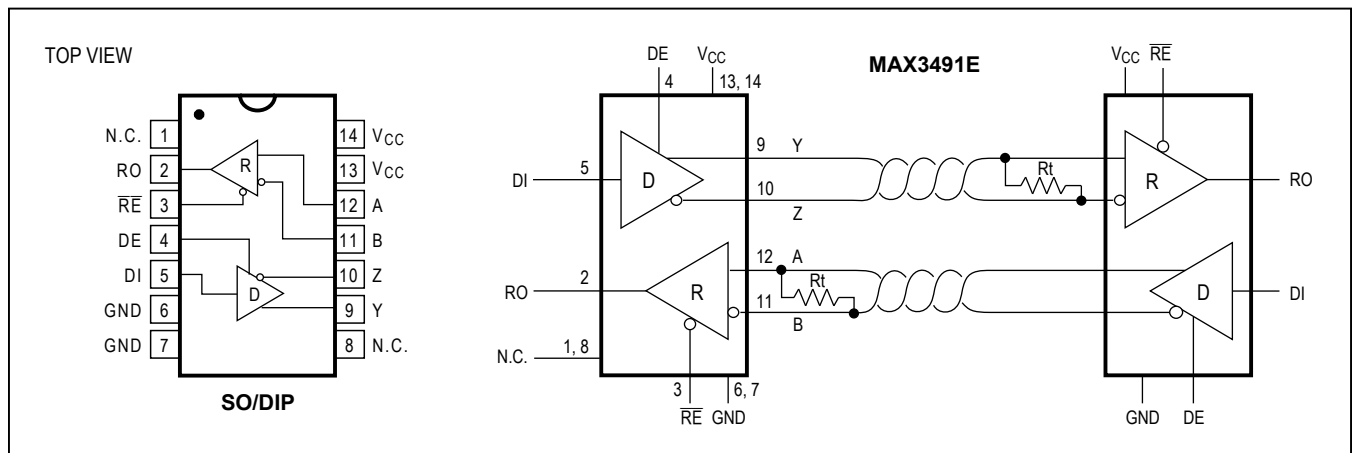

Figure 3. MAX3491E Pin Configuration and Typical Operating Circuit

MAX3483E/MAX3485E/
 MAX3486E/MAX3488E/
 MAX3490E/MAX3491E

3.3V-Powered, ±15kV ESD-Protected,
 12Mbps and Slew-Rate-Limited
 True RS-485/RS-422 Transceivers

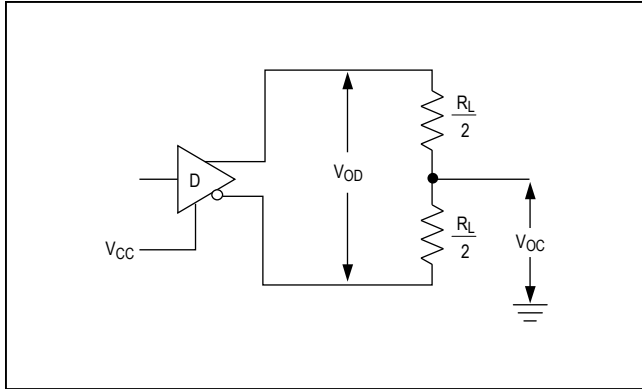

Figure 4. Driver V_{OD} and V_{OC}



Figure 5. Driver V_{OD} with Varying Common-Mode Voltage

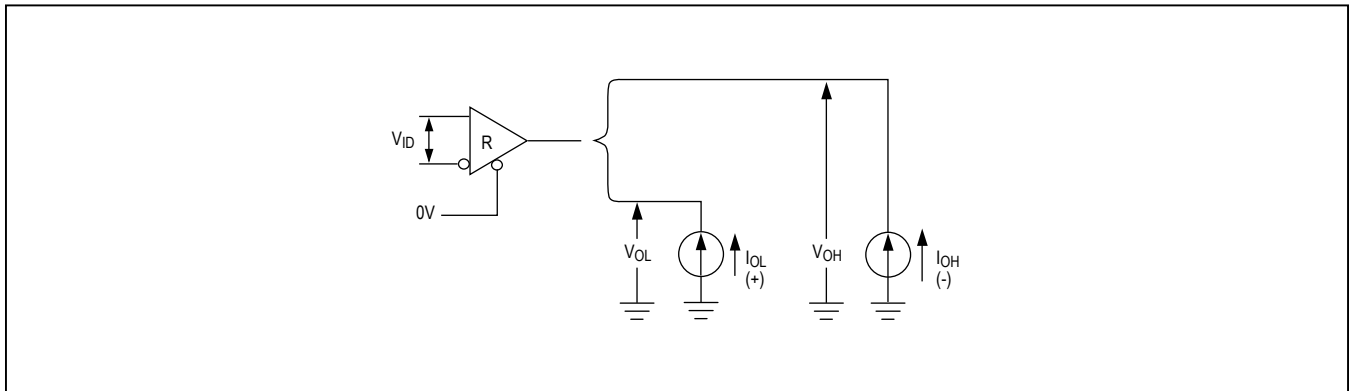

Figure 6. Receiver V_{OH} and V_{OL}

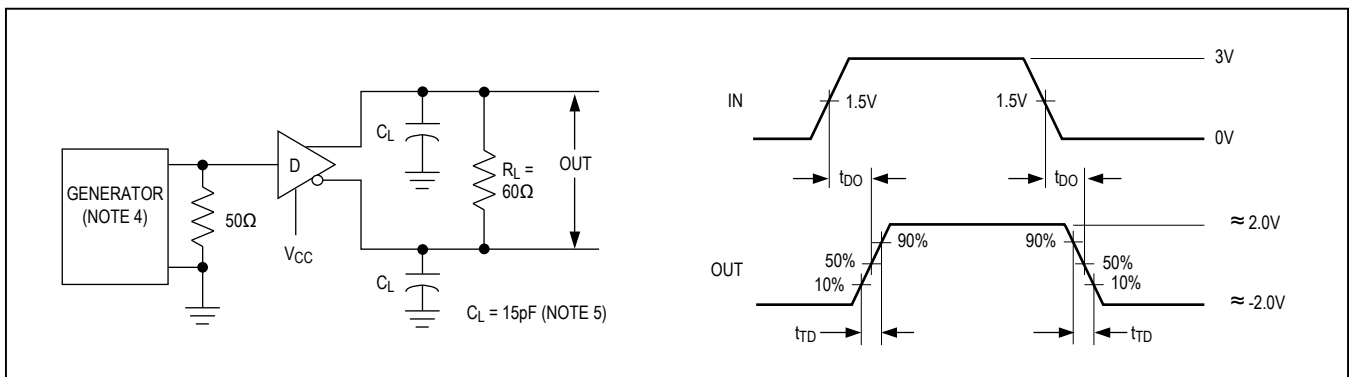

Figure 7. Driver Differential Output Delay and Transition Times

MAX3483E/MAX3485E/
 MAX3486E/MAX3488E/
 MAX3490E/MAX3491E

3.3V-Powered, ±15kV ESD-Protected,
 12Mbps and Slew-Rate-Limited
 True RS-485/RS-422 Transceivers

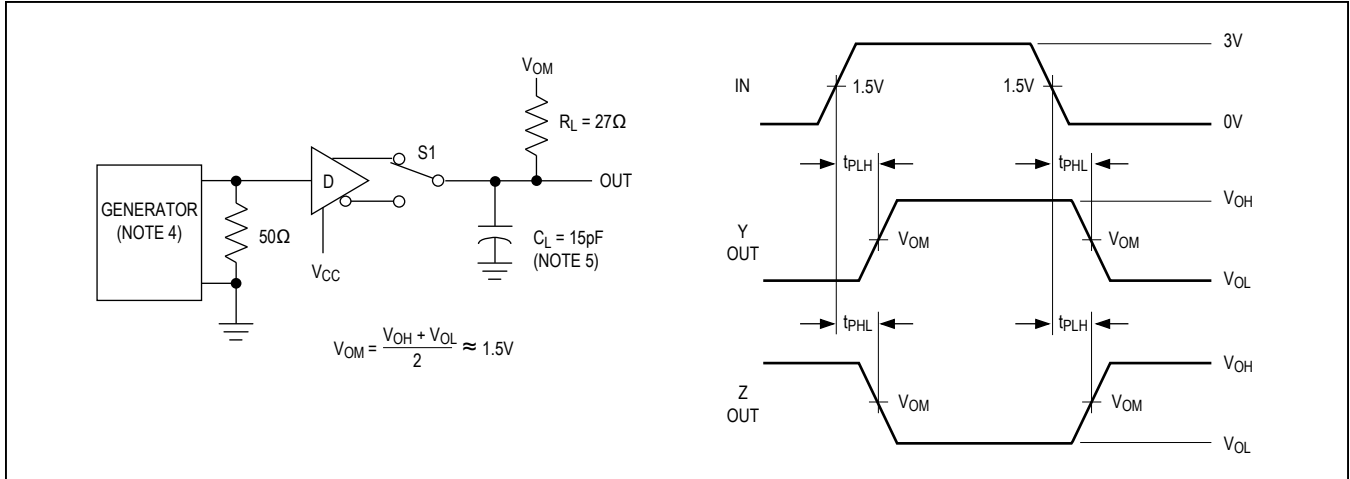

Figure 8. Driver Propagation Times

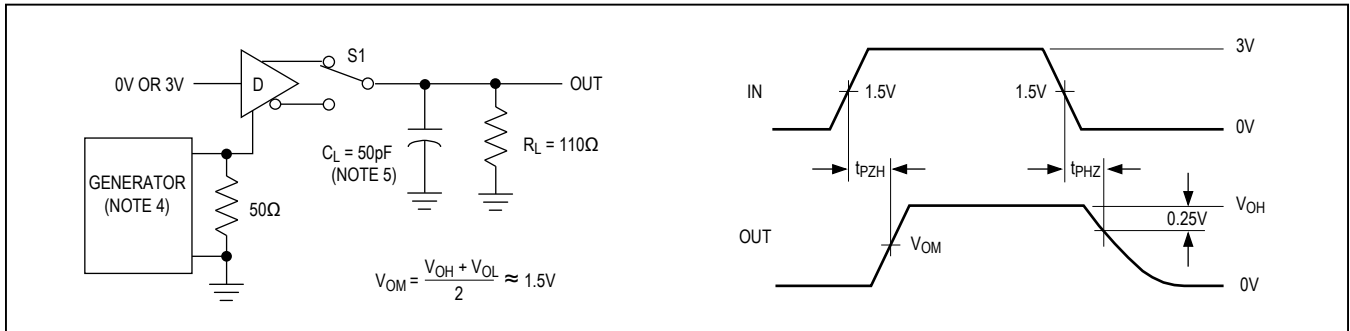

Figure 9. Driver Enable and Disable Times (t_{PZH} , t_{PSH} , t_{PHZ})

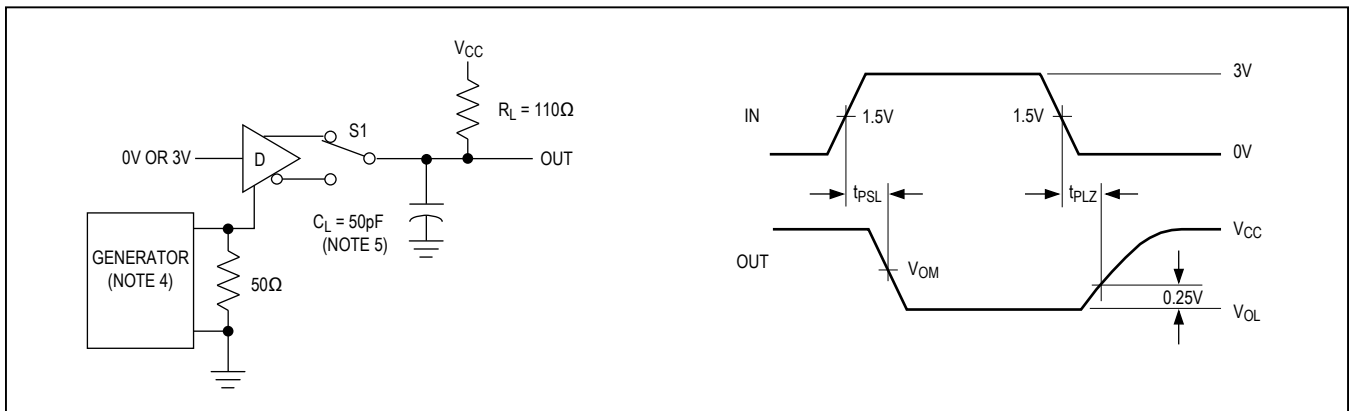

Figure 10. Driver Enable and Disable Times (t_{PZL} , t_{PSL} , t_{PLZ})

MAX3483E/MAX3485E/
MAX3486E/MAX3488E/
MAX3490E/MAX3491E

3.3V-Powered, ±15kV ESD-Protected,
12Mbps and Slew-Rate-Limited
True RS-485/RS-422 Transceivers

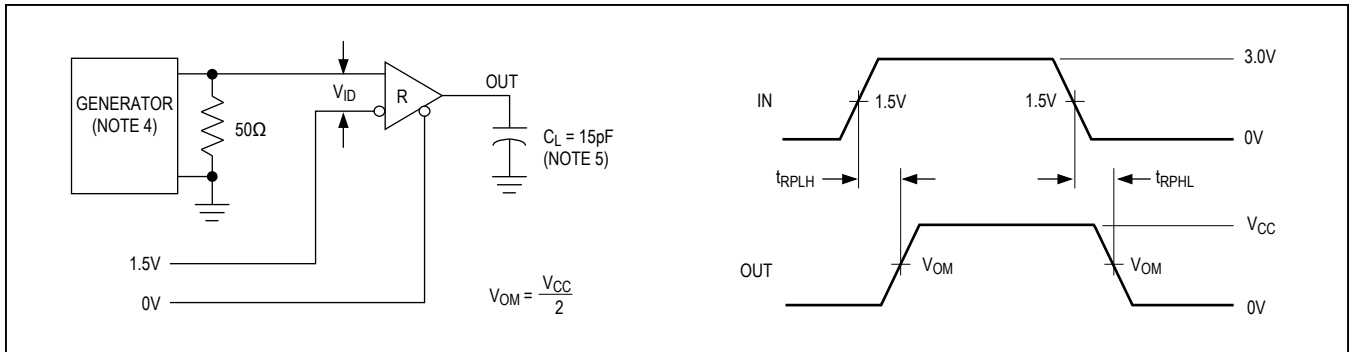

Figure 11. Receiver Propagation Delay

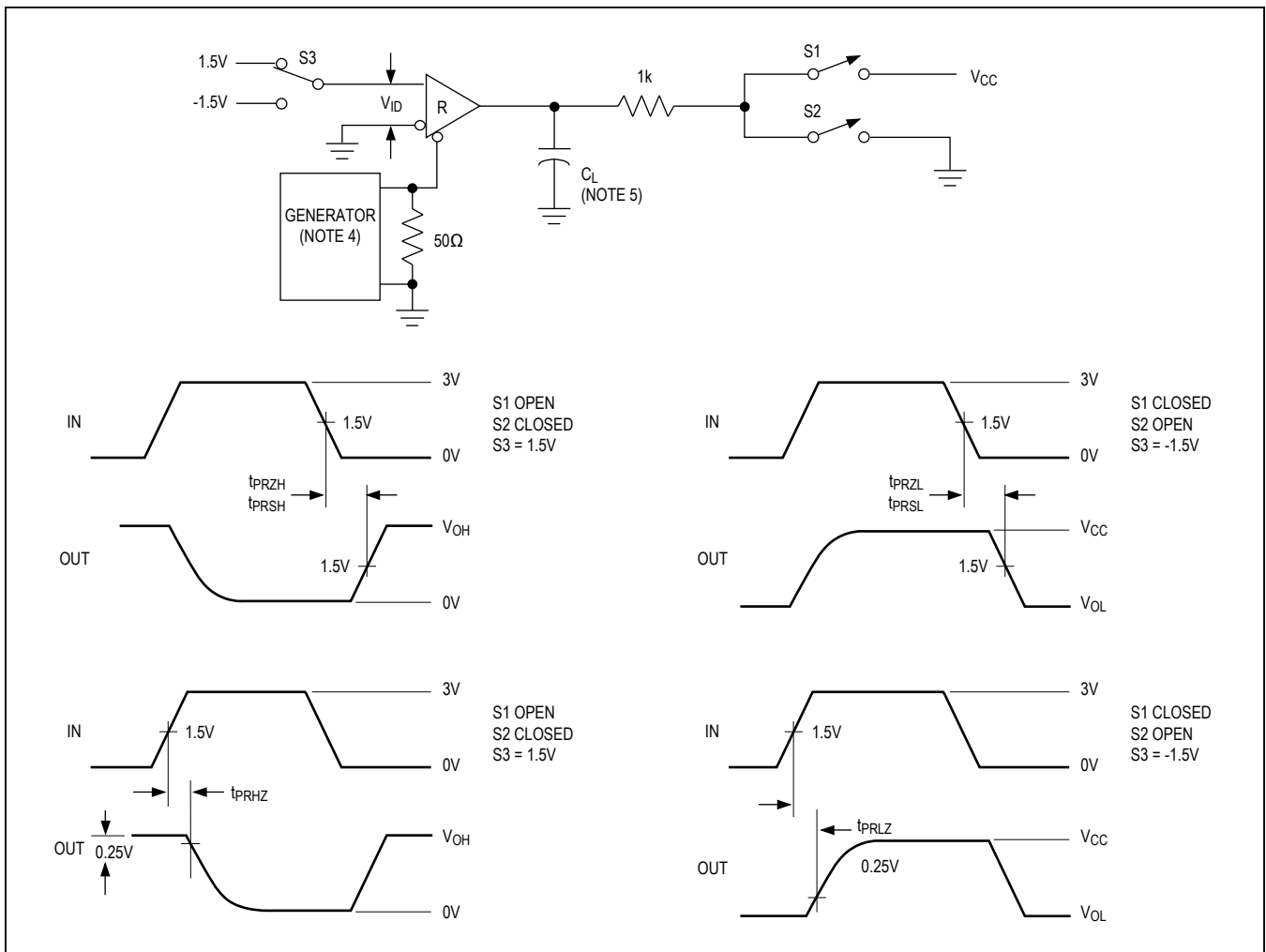

Figure 12. Receiver Enable and Disable Times

Note 4: The input pulse is supplied by a generator with the following characteristics: $f = 250\text{kHz}$, 50% duty cycle, $t_r \leq 6.0\text{ns}$, $Z_O = 50\Omega$.

Note 5: C_L includes probe and stray capacitance.

MAX3483E/MAX3485E/
MAX3486E/MAX3488E/
MAX3490E/MAX3491E

3.3V-Powered, ±15kV ESD-Protected,
12Mbps and Slew-Rate-Limited
True RS-485/RS-422 Transceivers

Function Tables

**Devices with Receiver/Driver Enable
(MAX3483E/MAX3485E/MAX3486E/MAX3491E)**

Table 1. Transmitting

INPUTS			OUTPUTS		MODE
\overline{RE}	DE	DI	B*	A*	
X	1	1	0	1	Normal
X	1	0	1	0	Normal
0	0	X	High-Z	High-Z	Normal
1	0	X	High-Z	High-Z	Shutdown

* B and A outputs are Z and Y, respectively, for full-duplex part (MAX3491E).

X = Don't care; High-Z = High impedance

Table 2. Receiving

INPUTS			OUTPUTS	MODE
\overline{RE}	DE	A, B	RO	
0	0*	$\geq +0.2V$	1	Normal
0	0*	$\leq -0.2V$	0	Normal
0	0*	Inputs Open	1	Normal
1	0	X	High-Z	Shutdown

* DE is a "don't care" (x) for the full-duplex part (MAX3491E).

X = Don't care; High-Z = High impedance

**Devices without Receiver/Driver Enable
(MAX3488E/MAX3490E)**

Table 3. Transmitting **Table 4. Receiving**

INPUT	OUTPUTS	
DI	Z	Y
1	0	1
0	1	0

INPUTS	OUTPUT
A, B	RO
$\geq +0.2V$	1
$\leq -0.2V$	0
Inputs Open	1

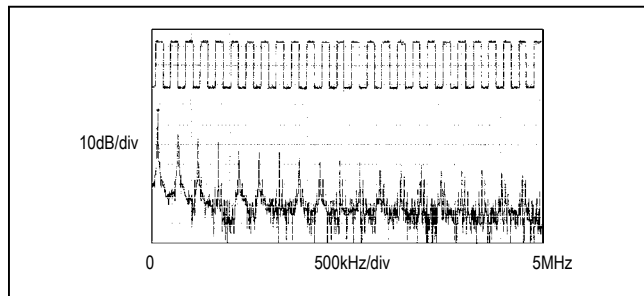

Figure 13. Driver Output Waveform and FFT Plot of MAX3485E/MAX3490E/MAX3491E Transmitting a 125kHz Signal

Applications Information

The MAX3483E/MAX3485E/MAX3486E/MAX3488E/MAX3490E/MAX3491E are low-power transceivers for RS-485 and RS-422 communications. The MAX3483E and MAX3488E can transmit and receive at data rates up to 250kbps, the MAX3486E at up to 2.5Mbps, and the MAX3485E/MAX3490E/MAX3491E at up to 12Mbps. The MAX3488E/MAX3490E/MAX3491E are full-duplex transceivers, while the MAX3483E/MAX3485E/MAX3486E are half-duplex. Driver Enable (DE) and Receiver Enable (\overline{RE}) pins are included on the MAX3483E/MAX3485E/MAX3486E/MAX3491E. When disabled, the driver and receiver outputs are high impedance.

Reduced EMI and Reflections (MAX3483E/MAX3486E/MAX3488E)

The MAX3483E/MAX3488E are slew-rate limited, minimizing EMI and reducing reflections caused by improperly terminated cables. Figure 13 shows the driver output waveform of a MAX3485E/MAX3490E/MAX3491E transmitting a 125kHz signal, as well as the Fourier analysis of that waveform. High-frequency harmonics with large amplitudes are evident. Figure 14 shows the same information, but for the slew-rate-limited MAX3483E/MAX3488E transmitting the same signal. The high-frequency harmonics have much lower amplitudes, and the potential for EMI is significantly reduced.

Low-Power Shutdown Mode (MAX3483E/MAX3485E/MAX3486E/MAX3491E)

A low-power shutdown mode is initiated by bringing both \overline{RE} high and DE low. The devices will not shut down unless both the driver and receiver are disabled (high impedance). In shutdown, the devices typically draw only 2nA of supply current.

For these devices, the t_{PSH} and t_{PSL} enable times assume the part was in the low-power shutdown mode; the t_{PZH} and t_{PZL} enable times assume the receiver or driver was disabled, but the part was not shut down.

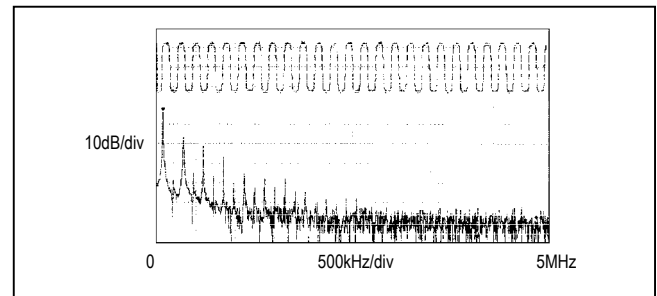

Figure 14. Driver Output Waveform and FFT Plot of MAX3483E/MAX3488E Transmitting a 125kHz Signal

MAX3483E/MAX3485E/
MAX3486E/MAX3488E/
MAX3490E/MAX3491E

3.3V-Powered, $\pm 15\text{kV}$ ESD-Protected,
12Mbps and Slew-Rate-Limited
True RS-485/RS-422 Transceivers



Figure 15. MAX3485E/MAX3490E/MAX3491E Driver Propagation Delay

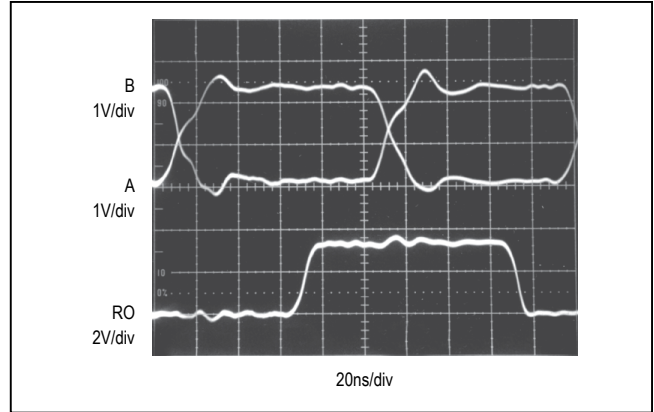

Figure 16. MAX3485E/MAX3490E/MAX3491E Receiver Propagation Delay Driven by External RS-485 Device

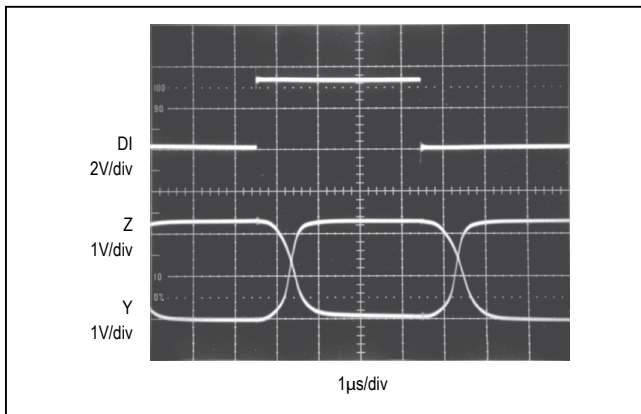

Figure 17. MAX3483E/MAX3488E Driver Propagation Delay

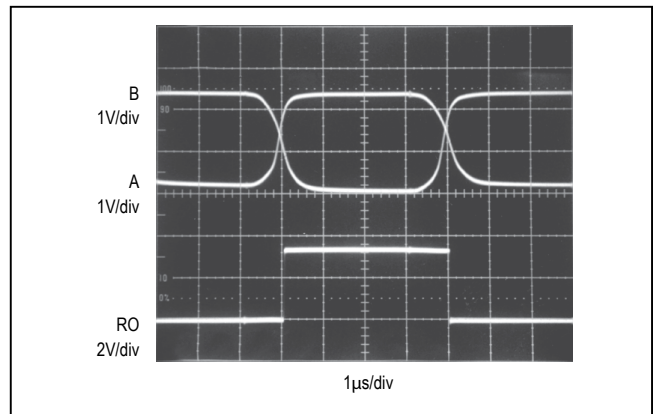

Figure 18. MAX3483E/MAX3488E Receiver Propagation Delay

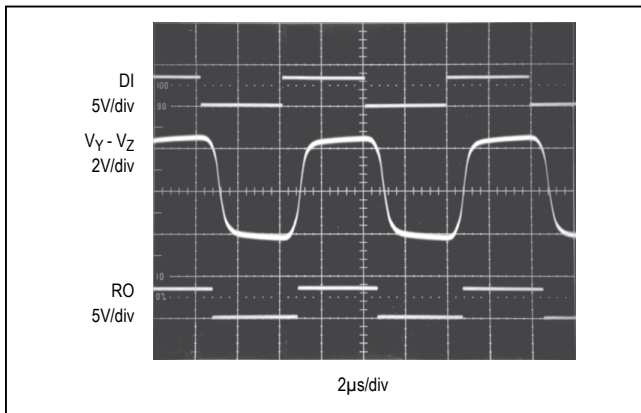

Figure 19. MAX3483E/MAX3488E System Differential Voltage at 125kHz Driving 4000 Feet of Cable

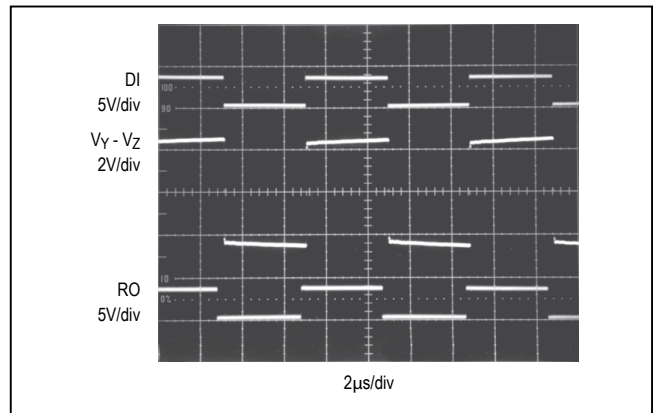

Figure 20. MAX3485E/MAX3490E/MAX3491E System Differential Voltage at 125kHz Driving 4000 Feet of Cable

MAX3483E/MAX3485E/
MAX3486E/MAX3488E/
MAX3490E/MAX3491E

3.3V-Powered, ±15kV ESD-Protected,
12Mbps and Slew-Rate-Limited
True RS-485/RS-422 Transceivers

Driver Output Protection

Excessive output current and power dissipation caused by faults or by bus contention are prevented by two mechanisms. A foldback current limit on the output stage provides immediate protection against short circuits over the whole common-mode voltage range (see *Typical Operating Characteristics*). In addition, a thermal shut-down circuit forces the driver outputs into a high-impedance state if the die temperature rises excessively.

Propagation Delay

Figures 15–18 show the typical propagation delays. Skew time is simply the difference between the low-to-high and high-to-low propagation delay. Small driver/receiver skew times help maintain a symmetrical mark-space ratio (50% duty cycle).

The receiver skew time, $|t_{PRLH} - t_{PRHL}|$, is under 10ns 20ns for the MAX3483E/MAX3488E). The driver skew times are 8ns for the MAX3485E/MAX3490E/MAX3491E, 12ns for the MAX3486E, and typically under 50ns for the MAX3483E/MAX3488E.

Line Length vs. Data Rate

The RS-485/RS-422 standard covers line lengths up to 4000 feet. For line lengths greater than 4000 feet, see Figure 21 for an example of a line repeater.

Figures 19 and 20 show the system differential voltage for parts driving 4000 feet of 26AWG twisted-pair wire at 125kHz into 120Ω loads.

For faster data rate transmission, please consult the factory.

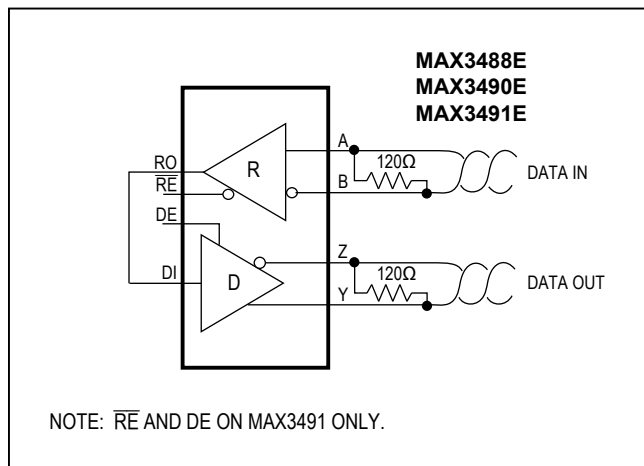

Figure 21. Line Repeater for MAX3488E/MAX3490E/MAX3491E

±15kV ESD Protection

As with all Maxim devices, ESD-protection structures are incorporated on all pins to protect against electrostatic discharges encountered during handling and assembly. The driver outputs and receiver inputs of the MAX3483E family of devices have extra protection against static electricity. Maxim’s engineers have developed state-of-the-art structures to protect these pins against ESD of ±15kV without damage. The ESD structures withstand high ESD in all states: normal operation, shutdown, and powered down. After an ESD event, Maxim’s E versions keep working without latchup or damage.

ESD protection can be tested in various ways; the transmitter outputs and receiver inputs of this product family are characterized for protection to the following limits:

- 1) ±15kV using the Human Body Model
- 2) ±8kV using the Contact-Discharge method specified in IEC 1000-4-2
- 3) ±15kV using IEC 1000-4-2’s Air-Gap method.

ESD Test Conditions

ESD performance depends on a variety of conditions. Contact Maxim for a reliability report that documents test setup, test methodology, and test results.

Human Body Model

Figure 22a shows the Human Body Model and Figure 22b shows the current waveform it generates when discharged into a low impedance. This model consists of a 100pF capacitor charged to the ESD voltage of interest, which is then discharged into the test device through a 1.5kΩ resistor.

IEC 1000-4-2

The IEC 1000-4-2 standard covers ESD testing and performance of finished equipment; it does not specifically refer to integrated circuits. The MAX3483E family of devices helps you design equipment that meets Level 4 (the highest level) of IEC 1000-4-2, without the need for additional ESD-protection components.

The major difference between tests done using the Human Body Model and IEC 1000-4-2 is higher peak current in IEC 1000-4-2, because series resistance is lower in the IEC 1000-4-2 model. Hence, the ESD withstand voltage measured to IEC 1000-4-2 is generally lower than that measured using the Human Body Model. Figure 23a shows the IEC 1000-4-2 model, and Figure 23b shows the current waveform for the ±8kV IEC 1000-4-2, Level 4 ESD contact-discharge test.

MAX3483E/MAX3485E/
MAX3486E/MAX3488E/
MAX3490E/MAX3491E

3.3V-Powered, ±15kV ESD-Protected,
12Mbps and Slew-Rate-Limited
True RS-485/RS-422 Transceivers

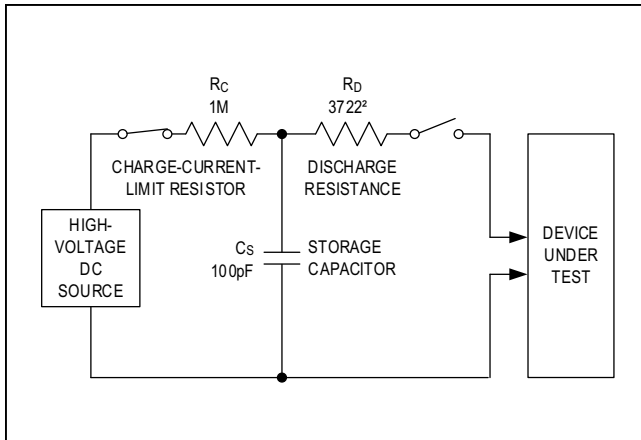

Figure 22a. Human Body ESD Test Model

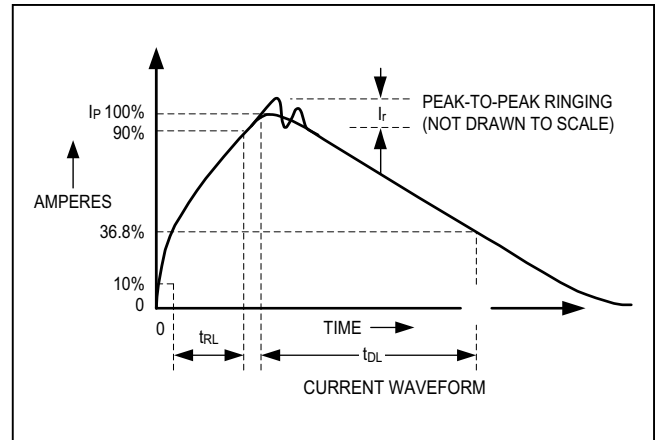

Figure 22b. Human Body Current Waveform

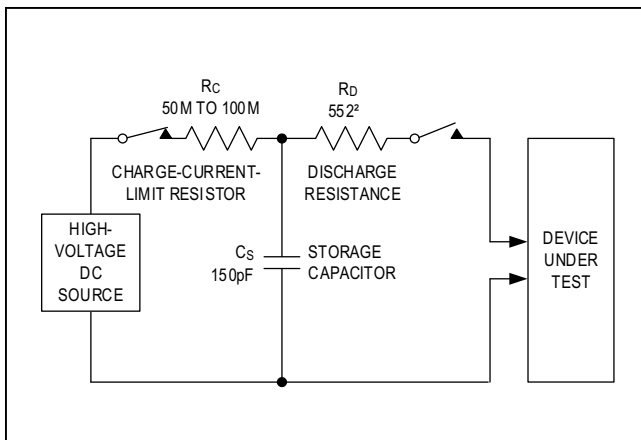

Figure 23a. IEC 1000-4-2 ESD Test Model

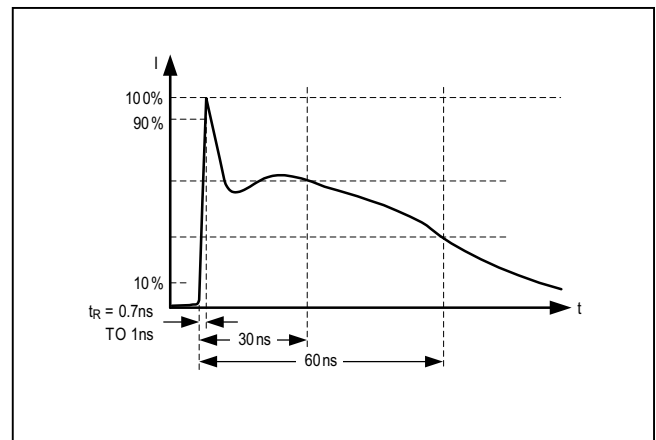

Figure 23b. IEC 1000-4-2 ESD Generator Current Waveform

The air-gap test involves approaching the device with a charged probe. The contact-discharge method connects the probe to the device before the probe is energized.

Machine Model

The Machine Model for ESD tests all pins using a 200pF storage capacitor and zero discharge resistance. Its objective is to emulate the stress caused when I/O pins are contacted by handling equipment during test and assembly. Of course, all pins require this protection, not just RS-485 inputs and outputs.

Typical Applications

The MAX3483E/MAX3485E/MAX3486E/MAX3488E/MAX3490E/MAX3491E transceivers are designed for bidirectional data communications on multipoint bus transmission lines. Figures 24 and 25 show typical network applications circuits. These parts can also be used as line repeaters, with cable lengths longer than 4000 feet, as shown in Figure 21.

To minimize reflections, the line should be terminated at both ends in its characteristic impedance, and stub lengths off the main line should be kept as short as possible. The slew-rate-limited MAX3483E/MAX3488E and the partially slew-rate-limited MAX3486E are more tolerant of imperfect termination.

MAX3483E/MAX3485E/
 MAX3486E/MAX3488E/
 MAX3490E/MAX3491E

3.3V-Powered, $\pm 15\text{kV}$ ESD-Protected,
 12Mbps and Slew-Rate-Limited
 True RS-485/RS-422 Transceivers

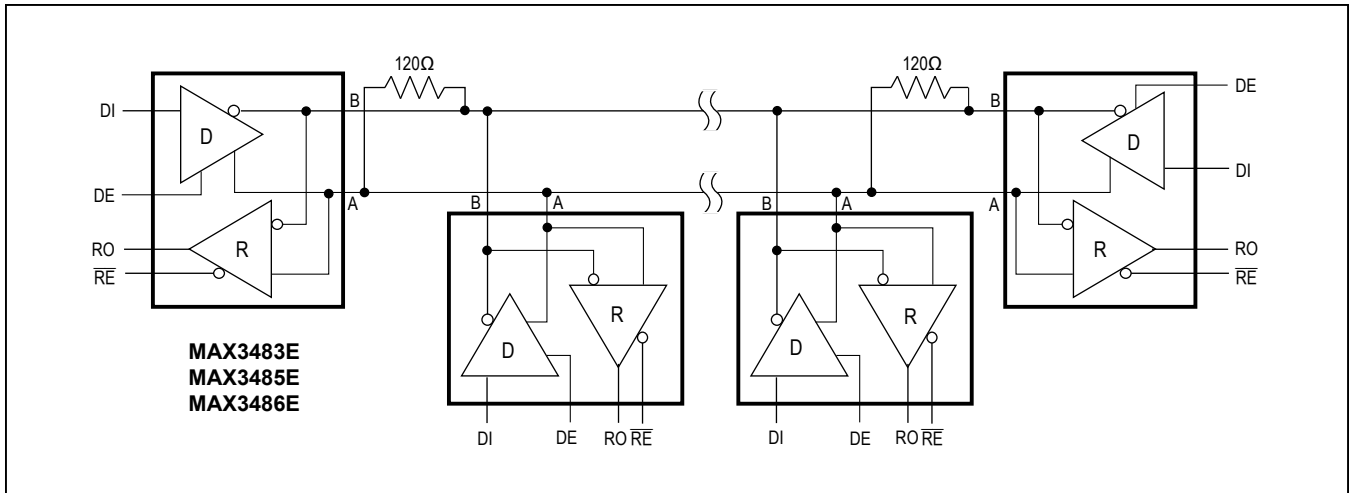

Figure 24. MAX3483E/MAX3485E/MAX3486E Typical RS-485 Network

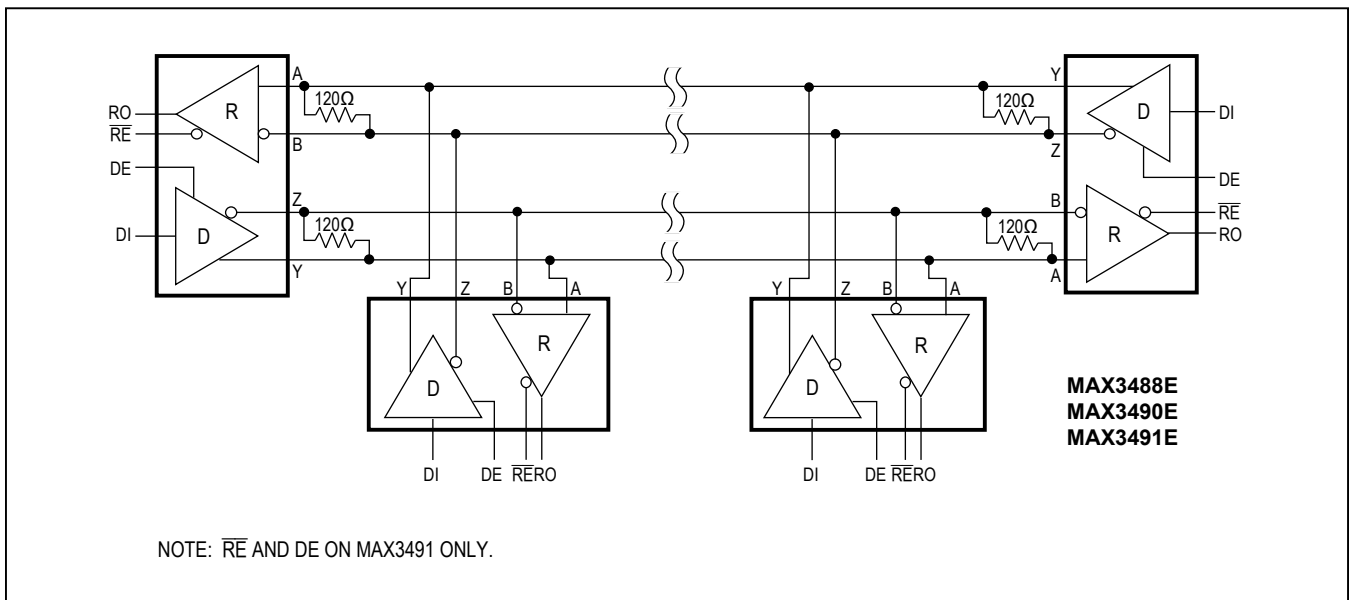

Figure 25. MAX3488E/MAX3490E/MAX3491E Full-Duplex RS-485 Network

MAX3483E/MAX3485E/
MAX3486E/MAX3488E/
MAX3490E/MAX3491E

3.3V-Powered, $\pm 15\text{kV}$ ESD-Protected,
12Mbps and Slew-Rate-Limited
True RS-485/RS-422 Transceivers

Ordering Information (continued)

PART	TEMP. RANGE	PIN-PACKAGE
MAX3485E CSA	0°C to +70°C	8 SO
MAX3485ECPA	0°C to +70°C	8 Plastic DIP
MAX3485EEESA	-40°C to +85°C	8 SO
MAX3485EEPA	-40°C to +85°C	8 Plastic DIP
MAX3486E CSA	0°C to +70°C	8 SO
MAX3486ECPA	0°C to +70°C	8 Plastic DIP
MAX3486EEESA	-40°C to +85°C	8 SO
MAX3486EEPA	-40°C to +85°C	8 Plastic DIP
MAX3488E CSA	0°C to +70°C	8 SO
MAX3488ECPA	0°C to +70°C	8 Plastic DIP
MAX3488EEESA	-40°C to +85°C	8 SO
MAX3488EEPA	-40°C to +85°C	8 Plastic DIP
MAX3490E CSA	0°C to +70°C	8 SO
MAX3490ECPA	0°C to +70°C	8 Plastic DIP
MAX3490EEESA	-40°C to +85°C	8 SO
MAX3490EEPA	-40°C to +85°C	8 Plastic DIP
MAX3491E CSA	0°C to +70°C	14 SO
MAX3491ECPD	0°C to +70°C	14 Plastic DIP
MAX3491EEESA	-40°C to +85°C	14 SO
MAX3491EEPD	-40°C to +85°C	14 Plastic DIP

Chip Information

TRANSISTOR COUNT: 761

MAX3483E/MAX3485E/
MAX3486E/MAX3488E/
MAX3490E/MAX3491E

3.3V-Powered, ±15kV ESD-Protected,
12Mbps and Slew-Rate-Limited
True RS-485/RS-422 Transceivers

Revision History

REVISION NUMBER	REVISION DATE	DESCRIPTION	PAGES CHANGED
0	4/99	Initial release	—
1	5/19	Updated <i>Absolute Maximum Ratings</i> and <i>Package Information</i> section	2

For pricing, delivery, and ordering information, please visit Maxim Integrated's online storefront at <https://www.maximintegrated.com/en/storefront/storefront.html>.

Maxim Integrated cannot assume responsibility for use of any circuitry other than circuitry entirely embodied in a Maxim Integrated product. No circuit patent licenses are implied. Maxim Integrated reserves the right to change the circuitry and specifications without notice at any time. The parametric values (min and max limits) shown in the Electrical Characteristics table are guaranteed. Other parametric values quoted in this data sheet are provided for guidance.

Mouser Electronics

Authorized Distributor

Click to View Pricing, Inventory, Delivery & Lifecycle Information:

[Analog Devices Inc.:](#)

[MAX3490ECSA+](#) [MAX3490EESA+](#) [MAX3490ECSA+T](#) [MAX3490EEPA+](#) [MAX3490EESA+T](#)