



GCA SERIES

AC Operated Gage Heads

SPECIFICATIONS

- ◆ Hermetically sealed housing
- ◆ 25 μ -inch [0.6 μ m] repeatability
- ◆ IEC IP68 rating to 1,000 PSI [70 bars]
- ◆ Long strokes up to ± 2 inches
- ◆ Hardened tool steel contact tip
- ◆ High side load resistance
- ◆ Long cycle life
- ◆ High temperature

The **GCA Series** heavy-duty gage heads enable high performance in environments containing moisture, dirt, and fluid contaminants. Gage heads are spring loaded LVDTs (Linear Variable Differential Transformers) with precision linear bearings.

These robust high-temperature gage heads allow measurements over long strokes up to ± 2 inches [± 50.8 mm]. The spring force is typically 9oz [255 grams] at fully compressed electrical stroke. A removable black-chromed, hardened tool steel tip is threaded (4-48UNF-2A) to the working end. Internal construction prevents the core and shaft from rotating as they move longitudinally. The integral electrical connector (welded) provides for easy installation and allows replacing a damaged cable without sacrificing the sensor. Installation and adjustment are facilitated by an external $\frac{1}{2}$ -20 mounting thread and the two locknuts supplied with each unit.

Like in most of our LVDTs, the GCA windings are vacuum impregnated with a specially formulated, high temperature, flexible resin, and the coil assembly is potted inside its housing with a two-component epoxy. This provides excellent protection against hostile environments such as high vibration and shock.

The ruggedness, long life cycle, and very high reliability of the GCA Series provide a low cost of ownership over the life of the equipment onto which they are installed. The one-piece front end (barrel which contains the bearing assembly), machined from solid stainless steel bar, coupled with a bronze bushing, has far greater resistance to bending forces and side loads compared to other designs. This is particularly important on the longer stroke versions; it reduces the common risk of probe damage/bending during installation or maintenance of industrial equipment. The GCA Series designs also require fewer parts and weld joints, thereby increasing overall structural integrity and reliability.

FEATURES

- ◆ All-welded stainless steel construction
- ◆ Resistant to harsh environments
- ◆ MS type connector (MIL-C-5015)
- ◆ High temperature
- ◆ High side loading resistance
- ◆ Long cycle life
- ◆ Calibration certificate supplied with each unit
- ◆ Air extend/spring retract available (Consult factory)

APPLICATIONS

- ◆ Factory automation
- ◆ Industrial printing equipment
- ◆ Steel mills
- ◆ Metal thickness gaging
- ◆ High temperature applications
- ◆ Environments requiring hermetically sealed transducers
- ◆ In-process measurements (feedback loop with PLC or CNC controller)

PERFORMANCE SPECIFICATIONS

ELECTRICAL SPECIFICATIONS						
Parameter	GCA 050	GCA 125	GCA 250	GCA 500	GCA 1000	GCA 2000
Stroke/gaging range	±0.050 [1.27]	±0.125 [3.17]	±0.25 [6.35]	±0.50 [12.7]	±1.0 [25.4]	±2.0 [50.8]
Sensitivity, V/V/inch	4.2	2.4	1.6	1.1	0.84	0.34
Sensitivity, mV/V/mm	165	94.5	63.0	43.3	33.1	13.4
Output at stroke ends (*)	210mV/V	300mV/V	400mV/V	550mV/V	840mV/V	680mV/V
Phase shift (nominal)	+6°	+5°	+5°	+2°	+1°	-1°
Input impedance (PRI)	430 Ω	1710 Ω	800 Ω	900 Ω	900 Ω	525 Ω
Output impedance (SEC)	950 Ω	1820 Ω	940 Ω	1150 Ω	2100 Ω	535 Ω
Input voltage	3 VRMS sine wave					
Input frequency range	400Hz to 10kHz					
Test input frequency	2.5kHz					
Non-linearity	±0.25% of FR, maximum					
Repeatability	25 micro-inches [0.06 microns]					
Null voltage	0.5% of FRO, maximum					
Frequency response (dynamic)	15Hz, maximum					
ENVIRONMENTAL SPECIFICATIONS & MATERIALS						
Operating temperature	-65°F to +300°F [-55°C to 150°C]					
Shock survival	1,000 g (11ms half-sine)					
Vibration tolerance	20 g up to 2kHz					
Housing material	AISI 400 Series stainless steel					
Electrical connector	6-pin MS type connector (MIL-C-5015)					
IEC 60529 rating	IP68 to 1,000 PSI [70 bars] with use of proper mating connector plug					

Notes:

All values are nominal unless otherwise noted

Dimensions are in inch [mm] unless otherwise noted

(*): Unit for output at stroke ends is millivolt per volt of excitation (input voltage)

FR: Full Range is the stroke range, end to end; FR=2xS for ±S stroke range

FRO (Full Range Output): Algebraic difference in outputs measured at the ends of the range

WIRING INFORMATION

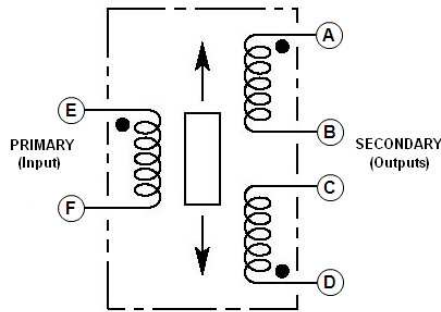

A through F: Connector pin assignments; Connect B to C for differential output

GCA SERIES

AC Operated Gage Heads

MECHANICAL SPECIFICATIONS

Parameter	GCA 050	GCA 125	GCA 250	GCA 500	GCA 1000	GCA 2000
Stroke/gaging range	±0.050 [1.27]	±0.125 [3.17]	±0.25 [6.35]	±0.5 [12.7]	±1 [25.4]	±2 [50.8]
Pre-travel	0.26 [6.6]	0.35 [8.9]	0.15 [3.8]	0.18 [4.6]	0.07 [1.8]	0.10 [2.5]
Over-travel (minimum)	0.15 [3.8]	0.15 [3.8]	0.15 [3.8]	0.90 [22.9]	0.15 [3.8]	0.00
Main body length "A"	1.91 [48.5]	2.75 [69.9]	3.61 [91.7]	5.30 [134.6]	7.56 [192.0]	10.89 [276.6]
Overall body length "B"	3.28 [83.31]	4.12 [104.7]	4.98 [126.5]	8.29 [210.6]	10.55 [268.0]	16.37 [415.8]
Plunger length "C" (fully extended)	4.33 [110.0]	5.14 [130.6]	6.02 [152.9]	10.76 [273.3]	13.01 [330.5]	20.94 [531.9]
Weight, Ounce	2.2 oz	2.9 oz	3.2 oz	5.0 oz	7.5 oz	13.0 oz
Weight, Gram	62 G	82 G	91 G	142 G	213 G	339 G
Spring force	Typically 9oz [255 grams] at fully compressed electrical stroke					

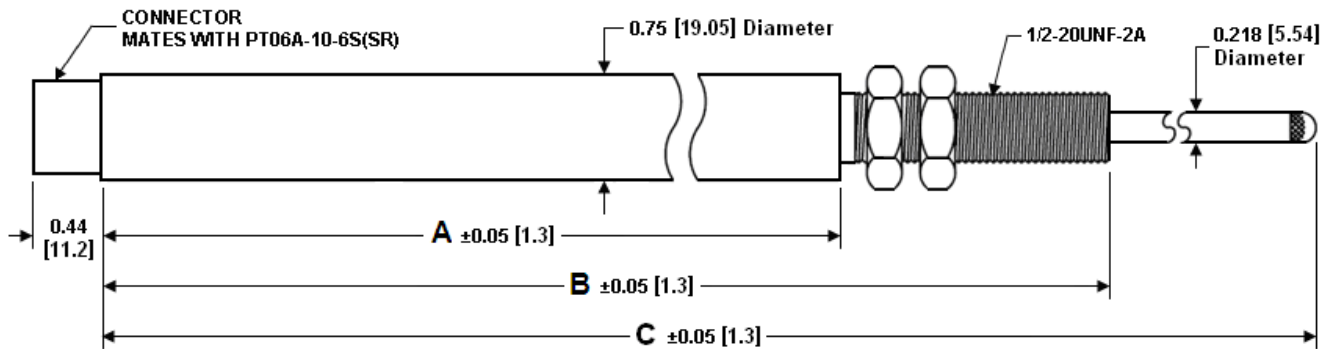

REPLACEMENT/OPTIONAL CONTACT TIPS

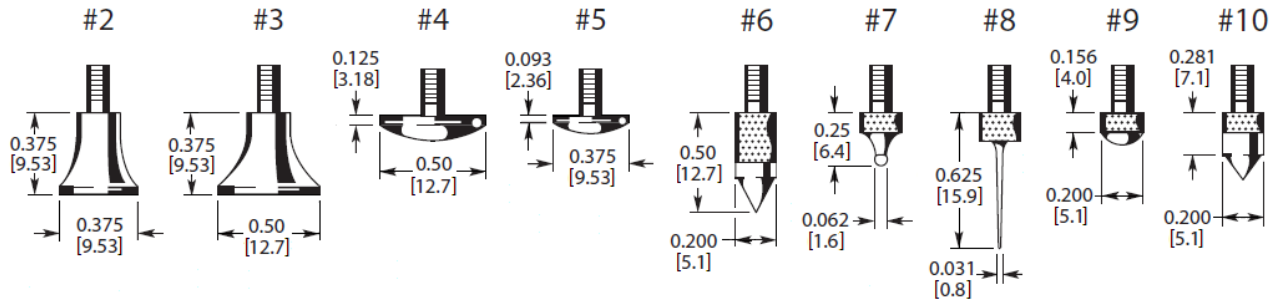

Dimensions are in inch [mm]

ORDERING INFORMATION

Description	Model	Part Number		
±0.050 inch gage head	GCA 050	02350499-000		
±0.125 inch gage head	GCA 125	02350500-000		
±0.25 inch gage head	GCA 250	02350501-000		
±0.5 inch gage head	GCA 500	02350502-000		
±1 inch gage head	GCA 1000	02350503-000		
±2 inch gage head	GCA 2000	02350614-000		
OPTIONS				
Air extend/spring retract gage head <i>(Consult factory)</i>	All GC Series	XXXXXXXX-150		
ACCESSORIES				
Mating connector kit	PT06A-10-6S(SR)	62101011-000		
Interconnect cable for LVM-110 and LiM 4-20 Signal Conditioners (1)	GCA to Stripped/Tinned	04290417-000		
Interconnect cable for IEM-422 Signal Conditioner (1)	GCA to PTO6A-10-6P	04290133-000		
Interconnect cable for ATA-2001 Signal Conditioner (1)	GCA to DB-9P	04290457-000		
Interconnect cable for MP-2000 Series Set-Point Controller (1)	GCA to 05BL5M	04290560-000		
Interconnect cable for LDM-1000/PML-1000 Signal Conditioners, 200°C (1)	GCA to Stripped/Tinned	04290595-000		
Replacement contact tips	Model	Part Number	Model	Part Number
	Contact Tip 2	67010005-000	Contact Tip 7	67010009-000
	Contact Tip 3	67010006-000	Contact Tip 8	67010010-000
	Contact Tip 4	67010002-000	Contact Tip 9	67010001-000
	Contact Tip 5	67010007-000	Contact Tip 10	67010011-000
	Contact Tip 6	67010008-000		

NORTH AMERICA

Measurement Specialties, Inc.,
a TE Connectivity company
Tel: 800-522-6752
Email: customercare.frm@te.com

EUROPE

Measurement Specialties (Europe), Ltd.,
a TE Connectivity Company
Tel: 800-440-5100
Email: customercare.bevx@te.com

ASIA

Measurement Specialties (China) Ltd.,
a TE Connectivity company
Tel: 0400-820-6015
Email: customercare.shzn@te.com

TE.com/sensorsolutions

Measurement Specialties, Inc., a TE Connectivity company.

Measurement Specialties, TE Connectivity, TE Connectivity (logo) and EVERY CONNECTION COUNTS are trademarks. All other logos, products and/or company names referred to herein might be trademarks of their respective owners.

The information given herein, including drawings, illustrations and schematics which are intended for illustration purposes only, is believed to be reliable. However, TE Connectivity makes no warranties as to its accuracy or completeness and disclaims any liability in connection with its use. TE Connectivity's obligations shall only be as set forth in TE Connectivity's Standard Terms and Conditions of Sale for this product and in no case will TE Connectivity be liable for any incidental, indirect or consequential damages arising out of the sale, resale, use or misuse of the product. Users of TE Connectivity products should make their own evaluation to determine the suitability of each such product for the specific application.

© 2015 TE Connectivity Ltd. family of companies All Rights Reserved.

Mouser Electronics

Authorized Distributor

Click to View Pricing, Inventory, Delivery & Lifecycle Information:

[TE Connectivity:](#)

[02350614-000](#)