



CONNECTIVE PERIPHERALS

USBC-H-422_485 - M PRO or - ISO PRO Series Serial Adapter

Data Sheet

Document Reference No.: CP_000078

Version 1.1

The USBC-H-422/485-M PRO or -ISO PRO, provides a simple method of adapting legacy serial devices with RS422 or RS485 interfaces to modern USB ports by incorporating the FTDI FT232H bridge chip. The ISO version features optical isolation to protect against electrical spikes and surges.

A power supply output of +5VDC @ up to 250mA is available on the 6-pin terminal block connector. Indicator LEDs provide functional status.

**Connective Peripherals Pte Ltd
178 Paya Lebar Road, #07-03 Singapore 409030
Tel.: +65 67430980 Fax: +65 68416071**

E-Mail (Support): support@connectiveperipherals.com Web: www.connectiveperipherals.com/products

Neither the whole nor any part of the information contained in, or the product described in this manual, may be adapted, or reproduced in any material or electronic form without the prior written consent of the copyright holder. This product and its documentation are supplied on an as-is basis and no warranty as to their suitability for any particular purpose is either made or implied. Connective Peripherals Pte Ltd will not accept any claim for damages howsoever arising as a result of use or failure of this product. Your statutory rights are not affected. This product or any variant of it is not intended for use in any medical appliance, device, or system in which the failure of the product might reasonably be expected to result in personal injury. This document provides preliminary information that may be subject to change without notice. No freedom to use patents or other intellectual property rights is implied by the publication of this document. Connective Peripherals Pte Ltd, 178 Paya Lebar Road, #07-03 Singapore 409030. Registered Number: 201617872E

Copyright © Connective Peripherals Pte Ltd

Table of Contents

1	Introduction	4
1.1	Functional Description	4
1.2	LED Description	5
1.3	Features	5
1.4	Performance Figures	6
1.5	Ordering Information	6
2	Installation	7
2.1	Example Applications and Configurations	7
2.1.1	Hardware Installation	7
2.1.2	Mounting	7
2.1.3	Wiring and Connection	8
2.2	Device Driver Installation	9
2.3	Configuration Via Software	9
2.3.1	Configuration via software for Windows (GUI)	10
2.3.2	Configuration via software for Windows (Command Line)	13
2.3.3	Configuration via software for Linux (GUI)	14
2.3.4	Configuration via software for Linux (Command Line)	14
3	Electrical details	15
3.1	USB Electrical Parameter	15
3.2	RS422/RS485	15
3.3	Power Output	16
4	Setting Recommendations	17
4.1	Data Transfer Rates versus Distance	17
4.2	Extra Fail-Safe (EFS)	17
4.3	120ohm Terminator (T120)	17
4.4	Grounding connection	18
4.4.1	USBC-H-422/485-M PRO (Non-Isolated Version)	18
4.4.2	USBC-H-422/485-M-ISO PRO (Isolated Version)	18
5	Physical Environment Details	19
5.1	Storage Temperature	19
5.2	Operating Temperature	19
6	Environmental Approvals & Declarations	20

6.1	EMI Compatibility	20
6.2	Safety	20
6.3	Reliability	20
6.4	Import / Export Information	20
7	Troubleshooting	21
7.1	Hardware	21
7.2	Device Driver	21
7.3	Technical Support	22
8	Contact Information	23
	Appendix A - List of Figures and Tables	24
	List of Figures	24
	List of Tables	24
	Appendix B - Revision History	25

1 Introduction

1.1 Functional Description

The USBC-H-422/485-M PRO and -ISO PRO provide a simple method of adapting legacy serial devices with RS422 or RS485 interfaces to modern USB ports. This is accomplished by incorporating the industry standard FTDI FT232H USB-Serial bridge chip which is USB 2.0 Hi-Speed (480Mbits/Second) and Full Speed (12Mbits/Second) compatible.

The PRO series edition is extremely flexible and allows the user to configure the serial interface mode selection and the operating settings entirely via a software utility tool instead of using DIP switches and jumpers.

Besides the RS422 or RS485 mode (mutually exclusive) configurable selection, there are total of 4 configurable selections based on the communication standard which are (i) Termination (120 Ω); (ii) Slew Rate (for enhanced distance and EMI emissions); (iii) Echo (only available for RS485 interface mode) and (iv) Extra-Fail-Safe mode (EFS, by enabling the bias resistors). All of these settings as well as data transmission traffic are visually confirmed by LED indication. It is possible to configure the serial port for data communication up to 3M baud rate with Slew Rate set to OFF.

It is recommended to utilise USBC-H-422/485-M-ISO PRO for applications where the devices need to be placed in a different building or in the same building but using a different power supply system. This is to protect the devices from the large lightning spikes & electric shock as well as to suppress any harmful electric noise.

Flexible mounting allows the USBC-H-422/485-M PRO or -ISO PRO to be used in a variety of applications, from a portable adapter to accompany a laptop to permanent installations in industrial, commercial, and retail locations. The USBC-H-422/485-M PRO or -ISO PRO serial adapter's electronic circuit board is mounted inside a metal enclosure which provides improved isolation performance as well as a more robust ESD protection.

The USBC-H-422/485-M PRO or -ISO PRO adapter requires USB device drivers, available free from <http://www.ftdichip.com/Drivers/VCP.htm> or <https://connectiveperipherals.com/pages/resources>, which allow the USBC-H-422/485-M PRO or -ISO PRO to appear as a Virtual COM Port (VCP). This allows existing serial communications software, such as Tera Term, to exchange data through the USBC-H-422/485-M PRO or -ISO PRO adapter to a legacy RS422/RS485 peripheral device.

Pin 5 of the terminal block connector can provide +5V DC power output with maximum 250mA.



Figure 1-1 - USBC-H-422/485-M PRO or -ISO PRO adapter

1.2 LED Description

The USBC-H-422/485-M PRO or -ISO PRO has a total of 10 LEDs to indicate power, configurable mode selection as well as data traffic according to the following table:

LED Label	LED Colour	Function	Description
CONFIG	Green	Operation Mode Indication	ON when device is in normal operation mode & flashes twice per second when it is in configuration programming mode.
RXD	Orange	RXD Activity Indication	Flashes when device is receiving the data from the attached RS422/RS485 peripheral device.
TXD	Red	TXD Activity Indication	Flashes when device is transmitting data to the attached RS422/RS485 peripheral device.
RS422	Green	RS422 Mode Indication	ON when device is in RS422 operation mode.
RS485	Green	RS485 Mode Indication	ON when device is in RS485 operation mode.
ECHO	Green	ECHO Mode Indication	ON when ECHO mode is enabled; device is in RS485 operation mode & receiving the same data as the transmitting data. OFF when ECHO mode is disabled, and the data transmitted is not received by RS485.
T120	Green	Termination Indication	ON when there is a 120Ω termination resistor between Data+ (A) & Data- (B) signals line for RS485; or between TXD+ & TXD-; RXD+ & RXD-; CTS## & CTS#- as well as RTS## & RTS#- for RS422. OFF when 120Ω line termination is disabled.
SLEW	Green	Slew Rate Indication	ON when slew rate control is enabled on the device, device can only transmit the data by RS422/RS485 up to 250k baud. OFF when slew rate control is disabled and device can transmit the data up to 3M baud.
EFS	Green	EFS mode Indication	ON when Extra-Fail-Safe mode is enabled whereby additional 750R pull-up and pull-down resistors are applied on the positive and negative differential lines, respectively. OFF when Extra-Fail-Safe mode is disabled.
IPWR	Green	5V Output Power Indication	For USBC-H-422/485-M PRO adapter, it is ON when 5V output power is stable. While for USBC-H-422/485-M-ISO PRO adapter, this LED indicates the power generation condition from the isolated 5V DC-DC converter power line; it will be ON normally, but if it is OFF, this indicates a failure in the DC-DC converter due to overload or component failure.

Table 1.1 – LED Description

1.3 Features

- Adds a high-speed RS422/485 serial port by connecting to USB
- Reversible USB type C connector ensures an excellent user experience.
- Easy plug & installation for RS422/RS485 device connection
- Works with USB 1.1, 2.0 & 3.0 Host and Hub ports
- Industry Standard FTDI chip set & device drivers for maximum compatibility
- Microsoft Windows® WHQL-certified, macOS, Linux and Windows CE device drivers
- Installs as a standard Windows COM port
- COM port number can be changed to any available COM port number, to support HyperTerminal, or any other serial communications software application running in Windows
- RS-485 data signals: A (Data+), B (Data-), GND
- RS-422 data signals: TXD-, TXD+, RXD+, RXD-, GND, RTS#-, RTS#+, CTS#+, CTS#-
- Powered by USB port. No external power adapter required.
- Pin 5 of terminal block connector can provide +5VDC output at 250mA
- Serial port speed up to 3Mbps
- Serial Communication Parameters
 - Data bits: 7, 8
 - Parity: None, Even, Odd, Mark, Space
 - Stop bits: 1, 2

- Flow control: None, RTS/CTS
- One 6-pin terminal block connector, two RJ45 connectors for RS485 serial communication and one DE-9P male connector for RS422/RS485 serial communication
- Clear LED indication of USB Data Traffic & configuration mode setting for monitoring port status & easy diagnostics
- Metal enclosure
- Operating temperature of 0°C to +70°C
- For USBC-H-422/485-M-ISO PRO, the RS422/485 port is optically isolated with 3kV DC optical isolation
- RS422/RS485 terminals are protected by surge protector to withstand electrostatic discharge and power surges up to ±25KV ESD
- UKCA, FCC and CE compliant.

1.4 Performance Figures

Parameter	Performance
USB Interface	USB 2.0 High Speed & full Speed compatible, USB 1.1 compliant
RS422/RS485 Interface	Standard Windows baud rates (300bps to 921.6Kbps) Custom baud rates (300bps to 3Mbps) through baud rate aliasing. See FTDI Application Note: https://ftdichip.com/wp-content/uploads/2020/08/AN_120_Aliasing_VCP_Baud_Rates.pdf

Table 1.2 - Performance Figures

1.5 Ordering Information

Part Number	Description
USBC-H-422/485-M PRO	High Speed USB compatible with USB type C receptacle connector to RS422/RS485; NON-Isolation version serial adapter
USBC-H-422/485-M-ISO PRO	High Speed USB compatible with USB type C receptacle connector to RS422/RS485; Isolation version serial adapter

Table 1.3 - Ordering Information

Note: For both 2 models the follow accessories we provide:

- USB2.0 standard A to USB Type-C cable (2meters) * 1;
- 35mm Din Rail Bracket(L=35mm) * 1;
- Screw M2.5*6mm * 2.

2 Installation

2.1 Example Applications and Configurations

2.1.1 Hardware Installation

There are no switches or jumpers to configure on the USBC-H-422/485-M PRO or -ISO PRO.

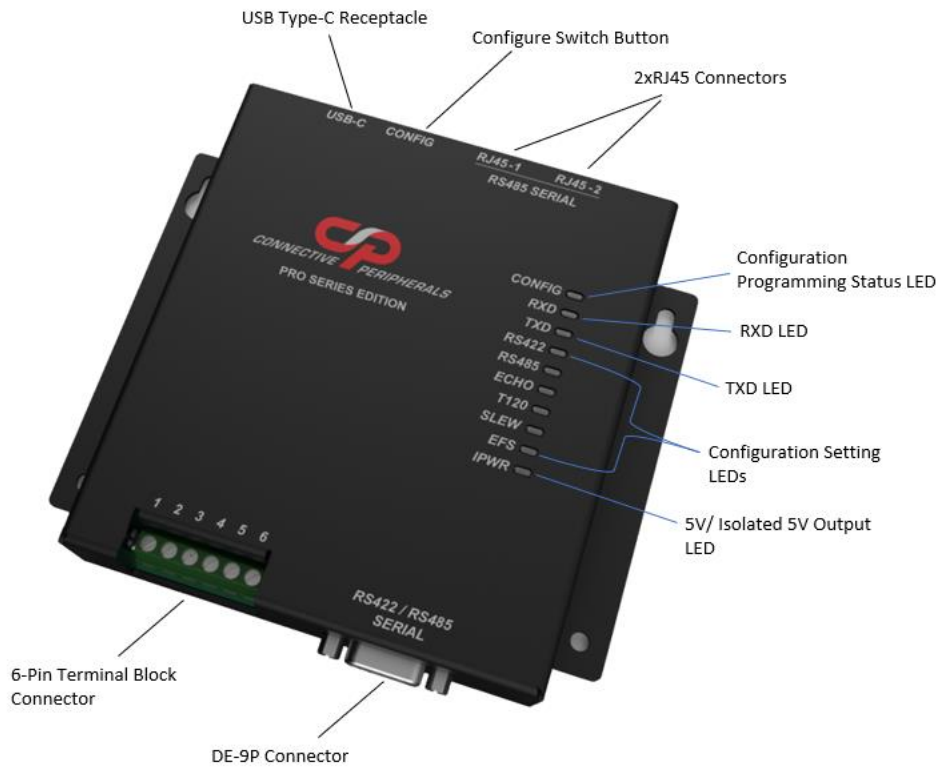

Figure 2-1 - USBC-H-422/485-M PRO or -ISO PRO's key component description

2.1.2 Mounting

The USBC-H-422/485-M PRO or -ISO PRO is provided with a 35mm standard DIN rail mount option. The DIN rail mount allows the USBC-H-422/485-M PRO or -ISO PRO to be permanently mounted to a wall or attached to a DIN rail.



Figure 2-2 - USBC-H-422/485-M PRO or -ISO PRO's Mounting

2.1.3 Wiring and Connection

The USBC-H-422/485-M PRO or -ISO PRO device is a downstream USB 2.0 High Speed Device. A standard USB Type "C" receptacle is mounted inside the USBC-H-422/485-M PRO or -ISO PRO device to facilitate connection to an upstream USB Host or Hub. Note: If a USB Hub is used, be sure it is "Self-Powered" with its own PSU, as the bus powered hub may not have enough current to supply to the device.

Insert the A-plug into an available USB Host or Hub port while insert the C-plug into the C-receptacle on the USBC-H-422/485-M PRO or -ISO PRO. Below table shows the pinout for the USB type C-receptacle connector.

Pin Number	Signal Name	Mating Sequence	Description
A1	GND	First	USB Ground
B1	GND	First	USB Ground
A4	VBUS	First	USB 5V Power provided from upstream USB Host or Hub
B4	VBUS	First	USB 5V Power provided from upstream USB Host or Hub
A5	CC1	Second	CC line; shorted to ground through 5.1kohm
B5	CC2	Second	CC line; shorted to ground through 5.1kohm
A6	DP1	Second	Data + for USB data signals
B6	DP2	Second	Data + for USB data signals
A7	DN1	Second	Data - for USB data signals
B7	DN2	Second	Data - for USB data signals
A8	SBU1 (N.C.)	Second	No connection
B8	SBU2 (N.C.)	Second	No connection
A9	VBUS	First	USB 5V Power provided from upstream USB Host or Hub
B9	VBUS	First	USB 5V Power provided from upstream USB Host or Hub
A12	GND	First	USB Ground
B12	GND	First	USB Ground
Shield	Case Ground	First	Shield (USB type C metal mating part); is shorted to ground

Table 2.1 - USB Type "C" Receptacle Pinout

Besides the USB C-receptacle, there are total 4 connectors; 1x terminal block connector, 1x DE-9P connector and 2x RJ45 connectors to be connected to RS422/RS485 devices.

Note: To avoid any unwanted issues, disconnect all RS485 devices from the USBC-H-422/485-M PRO or -ISO PRO when operating in RS422 mode and vice versa.

The terminal block connector is suitable for wire ended cable and the following table shows the pinout for the terminal block connector.

Pin	Signal Name	Type	Description
1	B/TXD-	Bi-Direction for RS485 or Output for RS422	B (Data -) for RS485 or TXD- for RS422
2	A/TXD+	Bi-Direction for RS485 or Output for RS422	A (Data +) for RS485 or TXD+ for RS422
3	RXD+	Input for RS422	RXD+ for RS422 or leave unconnected for RS485
4	RXD-	Input for RS422	RXD- for RS422 or leave unconnected for RS485
5	VOUT_5V	Output	5V DC Power Supply Output @ 250mA max; it is isolated 5V output if for USBC-H-422/485-M-ISO PRO
6	GND	GND	Ground or isolated ground; it is isolated ground if for USBC-H-422/485-M-ISO PRO

Table 2.2 - Terminal block connector pin assignment

DE-9P connector is compatible for the connection with RS422 or RS485 devices and the following table shows the pinout for the DE-9P connector.

Pin	Signal Name	Type	Description
1	B/TXD-	Bi-Direction for RS485 or Output for RS422	B (Data -) for RS485 or TXD- for RS422
2	A/TXD+	Bi-Direction for RS485 or Output for RS422	A (Data +) for RS485 or TXD+ for RS422
3	RXD+	Input	RXD+ for RS422
4	RXD-	Input	RXD- for RS422
5	GND	GND	Ground or isolated ground(See note)
6	RTS#-	Output	RTS#- for RS422
7	RTS#+	Output	RTS#+ for RS422
8	CTS#+	Input	CTS#+ for RS422
9	CTS#-	Input	CTS#- for RS422

Table 2.3 - DE-9P connector pin assignment

Note: Pin-5 is isolated ground for USBC-H-422/485-M-ISO PRO. If application required a VOUT_5V power supply output for the device and required no CTS/RTS handshake, customised versions of this also available. Users interested in customised versions of this should contact Connective Peripherals Sales - sales@connectiveperipherals.com.

2xRJ45 connectors are suitable for the connection with RS485 devices including DMX512 and the following table shows the pinout for the RJ45 connectors.

Pin	Signal Name	Type	Description
1	Data+ (A)	Bi-Direction	Data + for RS485
2	Data- (B)	Bi-Direction	Data - for RS485
3	N.C.	N.A.	No connection
4	N.C.	N.A.	No connection
5	N.C.	N.A.	No connection
6	N.C.	N.A.	No connection
7	GND	GND	Ground or isolated ground; it is isolated ground if for USBC-H-422/485-M-ISO PRO.
8	GND	GND	Ground or isolated ground; it is isolated ground if for USBC-H-422/485-M-ISO PRO.

Table 2.4 - RJ45 connectors' pin assignment

2.2 Device Driver Installation

The USBC-H-422/485-M PRO or -ISO PRO adapter drivers are available for download from: <https://connectiveperipherals.com/pages/resources> .

For driver installation instructions, please refer to the **Connective Peripherals USB to Serial Converters Driver Installation Guide (CP_000084)** which can see from here : [https://cdn.shopify.com/s/files/1/0434/1376/6295/files/USB to Serial Converters Driver Installation Guide.pdf](https://cdn.shopify.com/s/files/1/0434/1376/6295/files/USB_to_Serial_Converters_Driver_Installation_Guide.pdf).

2.3 Configuration Via Software

A free configuration utility is provided to change the configuration via software for Windows and Linux OS download from <https://connectiveperipherals.com/pages/resources>. Make sure to close all the operating applications for USBC-H-422/485-M PRO or -ISO PRO adapter before start to do configuration. To enter the configuration mode, press the Configure Switch Button until you see the CONFIG LED flashing. Then open up the CP Configuration Utility.exe and click the "Scan" button to search for the connected USBC-H-422/485-M PRO or -ISO PRO devices.

Note:

1. On Windows the utility will use the FTDI D2XX DLL automatically. The DLL is installed when the driver for an FTDI device is installed by Windows Update. Please disable the "VCP" driver before running the configuration utility, after config the device please enable the "VCP" to use the serial port. Follow below step to disable & enable the "VCP":

Device Manager ->Universal Serial Bus Controllers/USB Serial Converter/Properties ->Disable the "VCP."

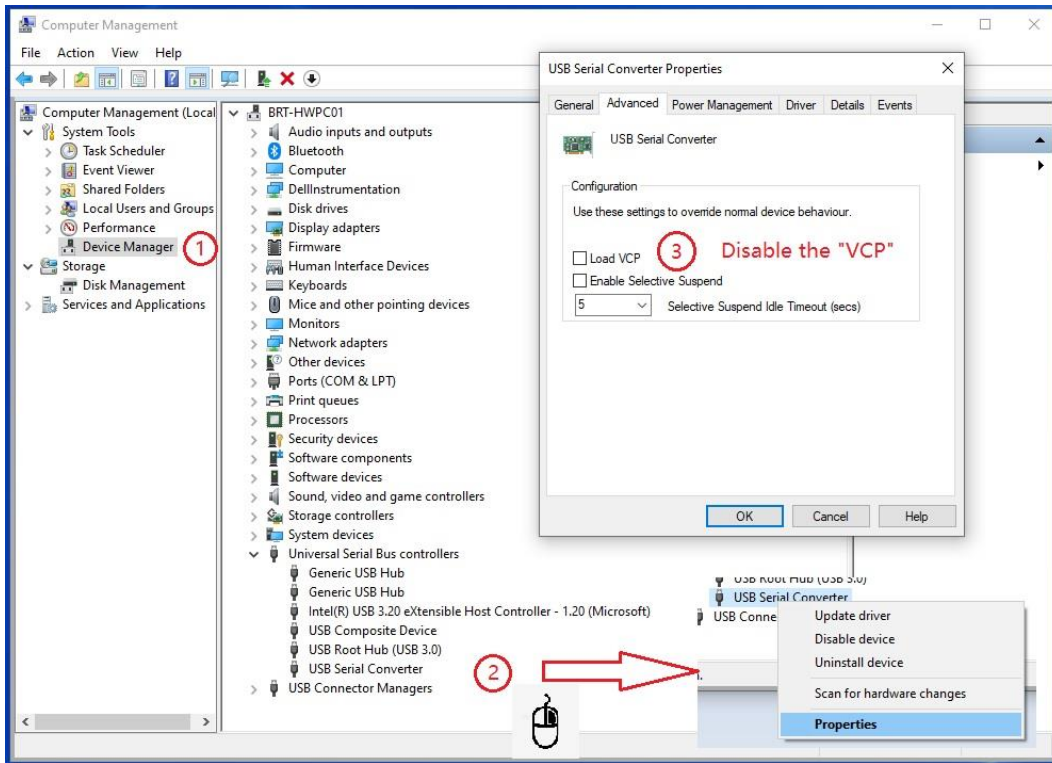

- On Linux, the library for D2XX (libftd2xx) must be installed manually. The install package is downloaded from the FTDI website. It is necessary to remove the ftdi_sio kernel module before using the utility as per the instruction in the library package.

2.3.1 Configuration via software for Windows (GUI)

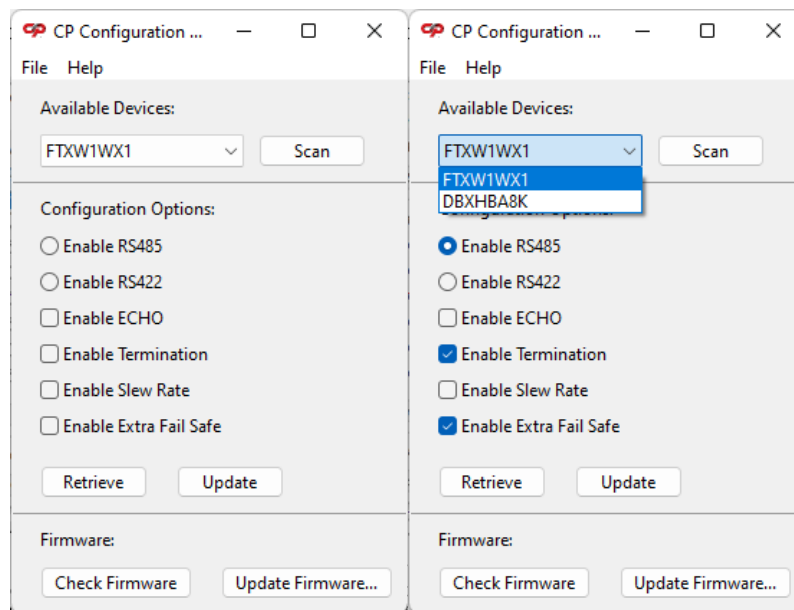

Figure 2-3 – CP Configuration Utility’s diagram (GUI)

All the connected USBC-H-422/485-M PRO or -ISO PRO devices will appear with their Serial Number in the COM Port dropdown list. Then select the desired device from the dropdown list to “Retrieve” the configuration setting data or “Update” the configuration setting data after finishing setting the configuration.

Note: The Configuration Utility is based on the serial number to config the device, please confirm the serial number showed in the Utility is the device you want to configure one.

To update the configuration setting data, check the box for the desired configuration selection, after that, click the “Update button,” if it is updated successfully then you will see a prompt out message as below –

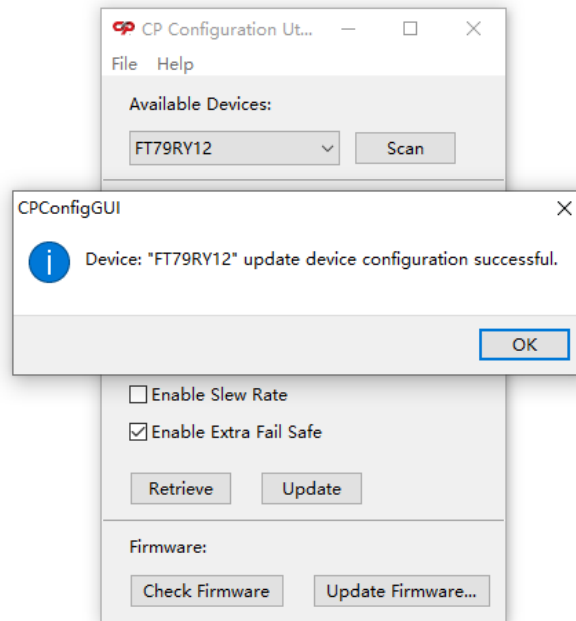

Figure 2-4 - CP Configuration Utility's “Successfully updated...” prompt out message

If the device fails to update the configuration settings data, then you will see a prompt out message as below.

Note:

1. Please kindly check whether the device was connected to another terminal, if yes please disconnect it and try again.
2. Please kindly check whether the device in configuration mode by checking the CONFIG LED flashing condition, if it is not in configuration mode, then please press the Configure Switch Button to enter into configuration mode.

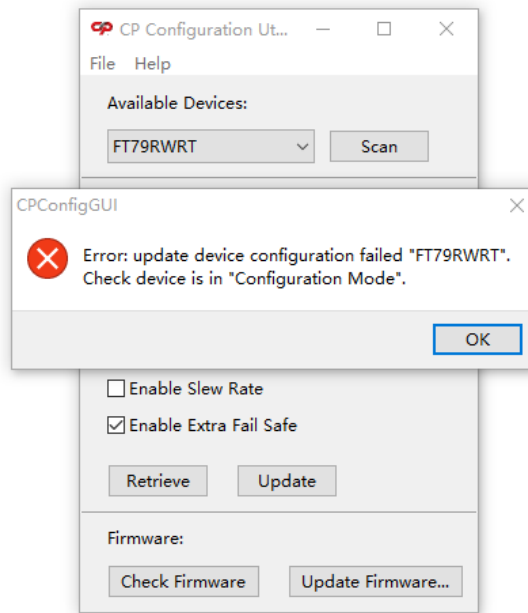

Figure 2-5 - CP Configuration Utility's "Update failed" prompt out message

Besides that, you may use the CP Configuration Utility to read out the current operating configuration setting data by pressing "Retrieve" button whilst the device is in configuration mode. Below is the prompt out message to indicate it has retrieved data successfully.

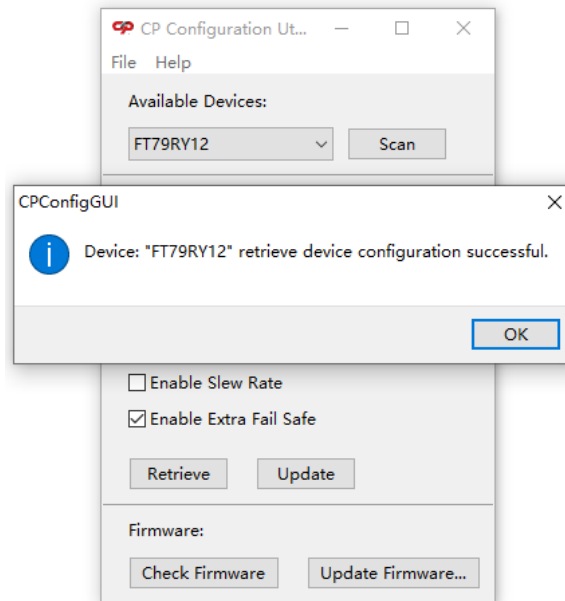

Figure 2-6 - CP Configuration Utility's "Read Successfully" prompt out message

If it has failed to retrieve the configuration setting data, then you will see a prompt out message as below.

Note:

1. Please kindly check whether the device was connected to another terminal, if yes please disconnect it and try again.
2. Please kindly check whether the device in configuration mode by checking the CONFIG LED flashing condition, if it is not in configuration mode, then please press the Configure Switch Button to enter into configuration mode.

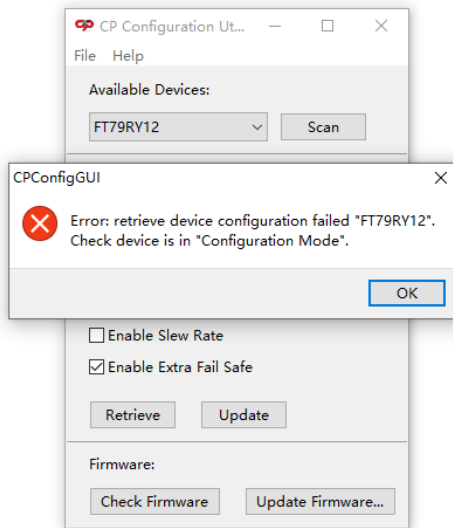

Figure 2-7 - CP Configuration Utility's "Read failed" prompt out message

It will remain in configuration mode after reading out the operating configuration data, so you may continue to update the configuration data using the check boxes to select the configuration parameter and then press "Update" button. If you would like to exit from this configuration mode, close the CP Configuration Utility and then unplug & plug in the USB cable to power cycle & reset the device in order to operate the device in normal operation mode.

2.3.2 Configuration via software for Windows (Command Line)

Locate to the Configuration Utility folder and run the **CPConfig.exe** file for details of the Command Line.

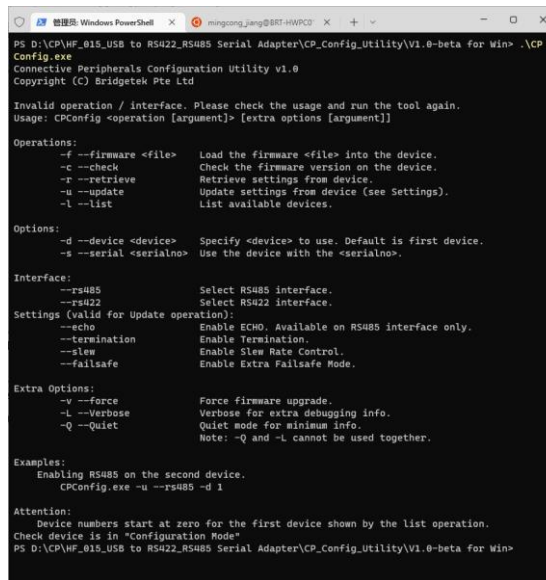

Figure 2-8 - CP Configuration Utility diagram (Command Line)

All the connected USBC-H-422/485-M PRO or -ISO PRO devices will appear with their Serial Number in the COM Port dropdown list. Can use ".\CPConfig.exe -l" to list all the connected devices. Then you can use the config commands to set the device.

```
PS D:\CP\HF_015_USB to RS422_RS485 Serial Adapter\CP_Config_UTILITY\V1.0-beta for Win> .\CP
Config.exe -l
Connective Peripherals Configuration Utility v1.0
Copyright (C) Bridgetek Pte Ltd

Device: Serial Number: Description:
0 FT79RY12 "USBC to RS422/RS485_ISO"
1 FT79RWRT "USBC to RS422/RS485_ISO"
```

Figure 2-9 - CP Configuration Utility's "Device list" output message

To update the configuration setting data, please follow the command examples as below:

```
Examples:
Enabling RS485 on the second device.
CPCConfig.exe -u --rs485 -d 1

Attention:
Device numbers start at zero for the first device shown by the list operation.
Check device is in "Configuration Mode"
```

Figure 2-10 - CP Configuration Utility's Command Format example

if it is updated successfully then you will see a message as below:

```
PS D:\CP\HF_015_USB to RS422_RS485 Serial Adapter\CP_Config_UTILITY\V1.0-beta for Win> .\CP
Config.exe -u --rs422 -d 0
Connective Peripherals Configuration Utility v1.0
Copyright (C) Bridgetek Pte Ltd

Update device configuration successful.
```

Figure 2-11- CP Configuration Utility's "Update Successfully" output message

If the device fails to update the configuration settings data, then you will see a message as below –

```
PS D:\CP\HF_015_USB to RS422_RS485 Serial Adapter\CP_Config_UTILITY\V1.0-beta for Win> .\CPCConfig.exe -u --rs485 -d -0
Connective Peripherals Configuration Utility v1.0
Copyright (C) Bridgetek Pte Ltd

Update device configuration failed.
Check device is in "Configuration Mode"
```

Figure 2-12- CP Configuration Utility's "Update Failed" output message

Note: Please kindly check whether the device is in configuration mode by checking the **CONFIG LED** flashing condition, if it is not in configuration mode, then please press the Configure Switch Button to enter into configuration mode.

2.3.3 Configuration via software for Linux (GUI)

Please refer to 2.3.1 [Configuration via software for Windows \(GUI\)](#)

2.3.4 Configuration via software for Linux (Command Line)

Please refer to 2.3.2 [Configuration via software for Windows \(CMD\)](#)

3 Electrical details

3.1 USB Electrical Parameter

Parameter	Description	Minimum	Typical	Maximum	Units	Conditions
USB_VCC	Input Power Voltage*	4.75	5.0	5.25	V	*Present when USB cable is attached, and USB Host or Hub powered.
I _{cc}	USB current	-	70	500	mA	For USBC-H-422/485-M PRO; without 250mA external load connected at terminal block connector
		-	320	500	mA	For USBC-H-422/485-M PRO; with 250mA external load connected at terminal block connector
		-	180	500	mA	For USBC-H-422/485-M-ISO PRO; without 250mA external load connected at terminal block connector
		-	430	500	mA	For USBC-H-422/485-M-ISO PRO; with 250mA external load connected at terminal block connector

Table 3.1 - USB Electrical Details

3.2 RS422/RS485

Parameter	Description	Minimum	Typical	Maximum	Units	Conditions
Receiver Input						
VCM	Common-mode input voltage range	-7		+12	V	
IN	Input Current			125	μA	VIN = +12V
				-100		VIN = -7V
VTH	Differential Threshold Voltage, VTH	-0.2		+0.2	V	
VIHYST	Input Hysteresis		25		mV	
RIN	Input Resistance, RIN	96	125		kΩ	
Transmitter Output						
VOD	Differential Output Voltage, dVOD	1.5		VOUT_5V	V	R = 27Ω (RS485)
		2.0		VOUT_5V	V	R = 50Ω (RS422)
ESD Tolerance						
ESD HBM	RS422/RS485 Inputs and Outputs		±25		kV	
EN61000-4-2ContactDischarge	RS422/RS485 Inputs and Outputs		±25		kV	
EN61000-4-2AirGapDischarge	RS422/RS485 Inputs and Outputs		±25		kV	

Table 3.2 - RS422/RS485 Electrical Details

3.3 Power Output

The USBC-H-422/485-M PRO or -ISO PRO assigns pin 5 of the 6-pin terminal block connector to provide +5V DC for an external device that requires power. The maximum allowable current that can be supplied from the USB bus is 500mA, including the circuitry of the USBC-H-422/485-M PRO or -ISO PRO itself, so up to 250mA may be used by the external device.

Parameter	Description	Minimum	Typical	Maximum	Units	Conditions
VOUT_5V	Output Power Voltage	4.25	5.0	5.25	V	For USBC-H-422/485-M PRO; The range is dependent on the USB port that the serial adapter is connected to.
		4.25	5.0	5.5	V	For USBC-H-422/485-M-ISO PRO; This is a DCDC output voltage, the maximum DC voltage may be up to 5.5V.
I _{out}	Output Power Current	0		250**	mA	**Overloading by drawing more than 250mA may cause the device to malfunction.

Table 3.3 - Power Output Option

4 Setting Recommendations

This section will share the basic knowledge about RS422 and RS485’s communication standard and the critical feature setting recommendations for the USBC-H-422/485-M PRO & USBC-H-422/485-M-ISO PRO to avoid errors during data transmission. As a user-friendly product, USBC-H-422/485-M PRO and USBC-H-422/485-M-ISO PRO have been designed with built-in features and configuration utility to make termination and failsafe easy to set without opening the unit or adding external resistors.

4.1 Data Transfer Rates versus Distance

USBC-H-422/485-M PRO & USBC-H-422/485-M-ISO PRO USB to RS422/RS485 serial adapters are suitable for long distance data communication up to 1200m with data rates at a maximum of 250kbps. For a connection up to 1200m, it is recommended to connect up to 4 devices if they operate with the data rates of 9600bps while up to 3 devices can be connected if they operate with a data rate of 250kbps. Besides that, for those applications required to operate under the highest data transfer rates of 3Mbps, it is recommended to connect up to a maximum of 300m with a maximum of 3 devices in a daisy chain. Nevertheless, for the application which is operating with data transfer rates less than 250kbps, it is recommended to always turn ON the Slew Rate setting as this will minimize the EMI emission as well as mitigate the adverse effects of imperfect transmission line termination which may be caused by stubs or mismatched cables.

4.2 Extra Fail-Safe (EFS)

The standard extra fail-safe (EFS) biasing is used to maintain the data bus in a known state (at logic high) when the bus in idle state (Tri-state; Hi-impedance, OFF). This is especially important for a Multi-Point application. It is recommended to always enable the EFS function for USBC-H-422/485-M PRO & USBC-H-422/485-M-ISO PRO devices as their drivers are switchable, always enabling the EFS function can prevent data errors occurring during the data transmission.

4.3 120ohm Terminator (T120)

The terminating 120ohm resistor across the differential data lines is used to match the nominal characteristic impedance of the data bus cabling so that the receiver at the end of the bus can see the maximum signal power & minimize the signal reflection as well as optimize the signal integrity. For an RS485 application, it is recommended to turn on the 120ohm terminator on the first device and last device among the devices connected in daisy chain (both ends of the daisy chain connection).

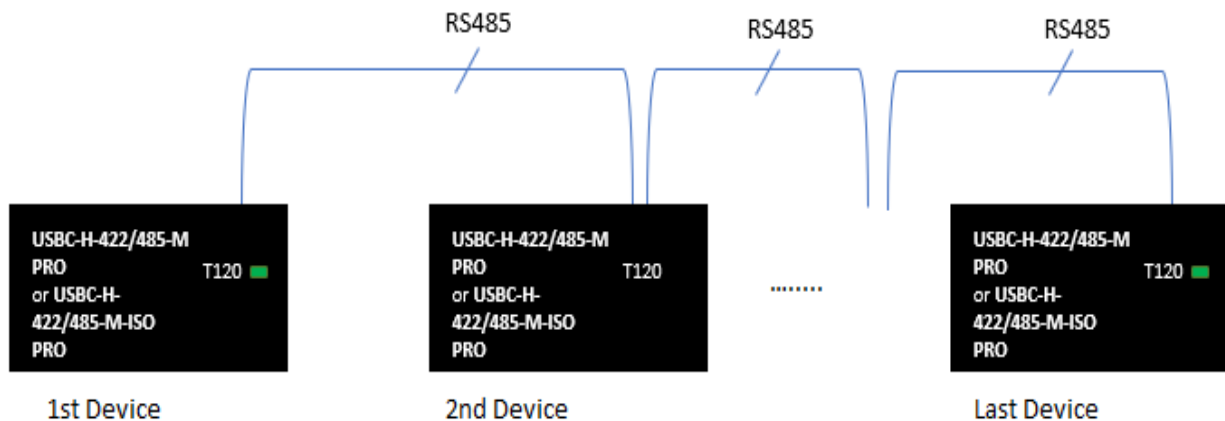

Figure 4-1 - Recommendation for 120ohm Terminator setting during RS485 communication with multipoint connection

For an RS422 application, typically it will be a point-to-point connection, and hence it is recommended to turn on the 120ohm terminator on the receiver side only for point-to-point connection.

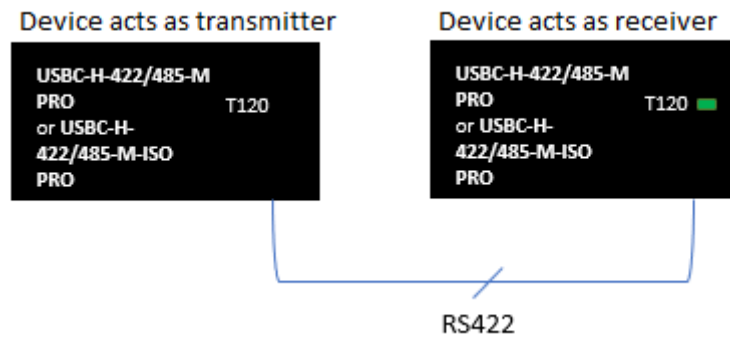

Figure 4-2 - Recommendation for 120ohm Terminator setting during RS422 communication with point-to-point connection

4.4 Grounding connection

The Connective Peripherals USB-C to RS422/RS485 High speed serial adapters are high speed USB to RS422 or RS485 serial adapter devices. Due to the cost issues, some users may try to avoid utilising an extra wire (GND). Hence, this section attempts to explain the design options available for grounding connections of RS422/RS485 data communication systems based on these versions. The first being a Non-Isolated designed while the second includes a complete galvanic isolated design between the USB ports and the RS422/RS485 peripheral devices.

4.4.1 USBC-H-422/485-M PRO (Non-Isolated Version)

There is no specific requirement for a grounding wire between the devices (USBC-H-422/485-M PRO) if they are in the same functional area and sharing the same power supply system. This is because these devices eventually will have the signal return through the identical system earth grounding wire and hence, the grounding's potential should be very low. Besides that, the USBC-H-422/485-M PRO includes internal surge protection at the RS422 & RS485 terminals which are able to divert the common mode surges to ground.

4.4.2 USBC-H-422/485-M-ISO PRO (Isolated Version)

For those applications where the devices are to be placed in different buildings or in the same building but using the different power supply systems, it is recommended to use the isolated USBC-H-422/485-M-ISO PRO in the application. If the devices are not connected to the same metal system grounding, there is a requirement to have a grounding wire connected between the devices. In a case where there is no grounding wire connected between RS422 or RS485 terminal, there is a very high probability that some data corruption or miscommunication may occur, especially during a lightning storm as the ground potential developed between the devices becomes significant.

5 Physical Environment Details

5.1 Storage Temperature

Parameter	Description	Minimum	Typical	Maximum	Units	Conditions
T	Storage Temperature Range	-20		+75	°C	

Table 5.1 - Storage Temperature

5.2 Operating Temperature

Parameter	Description	Minimum	Typical	Maximum	Units	Conditions
T	Operating Temperature Range	0		+70	°C	

Table 5.2 - Operating Temperature

6 Environmental Approvals & Declarations

6.1 EMI Compatibility

UKCA, FCC and CE

The USBC-H-422/485-M PRO or -ISO PRO has been tested to be compliant with UKCA, FCC Part 15 Subpart B and European EMC Directive.



NOTE: This is a Class B product. In a domestic environment, this product may cause radio interference, in which case the user may be required to take adequate measures.



NOTE: This equipment has been tested and found to comply with the limits for a Class B digital device, pursuant to Part 15 of the FCC Rules. These limits are designed to provide reasonable protection against harmful interference in a residential installation. This equipment generates, uses, and can radiate radio frequency energy and, if not installed and used in accordance with the instructions, may cause harmful interference to radio communications. However, there is no guarantee that interference will not occur in a particular installation. If this equipment does cause harmful interference to radio or television reception, which can be determined by turning the equipment off and on, the user is encouraged to try to correct the interference by one or more of the following measures:

- Reorient or relocate the receiving antenna.
- Increase the separation between the equipment and receiver.
- Connect the equipment into an outlet on a circuit different from that to which the receiver is connected.
- Consult the dealer or an experienced radio/TV technician for help.

6.2 Safety

The USBC-H-422/485-M PRO or -ISO PRO is defined as Limited Power Supply (LPS) device, with operating voltages under 60VDC.

6.3 Reliability

The USBC-H-422/485-M PRO or -ISO PRO is designed as a robust USB-Serial adapter for use in many environments. There are no user-serviceable parts. Any failure will require a replacement of the unit.

6.4 Import / Export Information

Import / Export Information	
Country of Origin	China
Harmonized System Code	8542.90.0000
Product Description	USB2.0 Type C High Speed to RS422/RS485 serial adapter (Isolated or Non-Isolated version)
USA ECCN	EAR99 – No License Required

Table 6.1 - Import / Export Information

7 Troubleshooting

7.1 Hardware

Cables are the most common sources of trouble with external devices.

Check the following:

- USB cable supported USB2.0 high speed is required & it should be able to sync the data at 480Mbps transfer speed.
- USB cable is properly inserted at both ends
- Computer power is ON
- Computer is not in Sleep or Standby
- If a USB Hub is used, be sure it is set for "Self-Powered" operation
- If a USB Hub is used, be sure all cables are properly inserted
- If all the above are OK, the PWR LED should be lit, indicating the device has been powered up and ready for communication.

RS485 cables – check the following:

- Check for specific handshake requirements of your RS485 peripheral.
- Because there are no handshake signals, ensure the application is set to "No Hardware Handshake," or equivalent.

RS422 cables – check the following:

- Check for specific handshake requirements of your RS422 peripheral.
- Because there are either "None" or RTS/CTS handshake signal could be selected for RS422 mode, ensure the application is set to "None" handshake or "RTS/CTS" handshake or equivalent.

7.2 Device Driver

Ensure the latest device driver is in use. See <http://www.ftdichip.com/Drivers/VCP.htm>.

If other devices with FTDI chips are installed in the system, check with all manufacturers of these devices for the latest device drivers.

See the FTDI installation guides for additional details: <http://ftdichip.com/Documents/InstallGuides.htm>
Common Windows Device Driver Troubles:

- **DEVICE TIMES OUT:** The default settings of the device driver assume typical data transfers of hundreds to thousands or more bytes at a given time. Some applications, such as a GPS device, only send data in short packets, often only a few bytes. If this is the case, it may be necessary to adjust the driver's buffer size and/or latency timer to smaller values. These values can be adjusted through the Advanced driver options (see [FTDI AN 107](#)). The buffer size can be reduced to 64 bytes. The latency timer can be set as low as 2ms. A setting of 1ms will cause unnecessary USB traffic and could adversely affect data transmission.
- **ERRATIC MOUSE POINTER:** The device driver defaults to query an attached device to find out whether it is a mouse or modem, consistent with native COM port operation. Some RS485 peripherals constantly send short packets of data, causing the host system to "think" a mouse or modem has been attached. These short packets will interfere with normal mouse operation causing the pointer to jump around the screen. If this happens, disconnect the RS485 device and *uncheck the Serial Enumerator* option, also found on the Advanced Driver Options (see [FTDI AN 107](#)).
- **COM PORT IN USE:** Windows keeps track of all COM port assignments. If multiple products have been connected to a single system, the COM port number will increase, even if the other devices are not attached. If the higher COM port assignments are not acceptable for the application, known unused COM port numbers should be uninstalled according to the FTDI installation guide: <http://ftdichip.com/Documents/InstallGuides.htm>.

7.3 Technical Support

Technical support may be obtained from your nearest Connective Peripherals office. See details below.

E-Mail (Support): support@connectiveperipherals.com

Web: <http://www.connectiveperipherals.com/products>

8 Contact Information

Global Headquarters – Singapore

Connective Peripherals Pte Ltd
178 Paya Lebar Road
#07-03
Singapore 409030

Tel: +65 67430980
Fax: +65 68416071

E-Mail (Sales)	sales@connectiveperipherals.com
E-Mail (Support)	support@connectiveperipherals.com
Web Site URL	http://www.connectiveperipherals.com
Web Shop URL	http://www.connectiveperipherals.com

Appendix A - List of Figures and Tables

List of Figures

Figure 1-1 - USBC-H-422/485-M PRO or -ISO PRO adapter.....	4
Figure 2-1 - USBC-H-422/485-M PRO or -ISO PRO's key component description.....	7
Figure 2-2 - USBC-H-422/485-M PRO or -ISO PRO's Mounting	7
Figure 2-3 - CP Configuration Utility's diagram (GUI).....	10
Figure 2-4 - CP Configuration Utility's "Successfully updated..." prompt out message.....	11
Figure 2-5 - CP Configuration Utility's "Update failed" prompt out message.....	12
Figure 2-6 - CP Configuration Utility's "Read Successfully" prompt out message	12
Figure 2-7 - CP Configuration Utility's "Read failed" prompt out message.....	13
Figure 2-8 - CP Configuration Utility diagram (Command Line).....	13
Figure 2-9 - CP Configuration Utility's "Device list" output message	14
Figure 2-10 - CP Configuration Utility's Command Format example	14
Figure 2-11- CP Configuration Utility's "Update Successfully" output message	14
Figure 2-12- CP Configuration Utility's "Update Failed" output message.....	14
Figure 4-1 - Recommendation for 120ohm Terminator setting during RS485 communication with multipoint connection.....	17
Figure 4-2 - Recommendation for 120ohm Terminator setting during RS422 communication with point-to-point connection	18

List of Tables

Table 1.1 - LED Description	5
Table 1.2 - Performance Figures	6
Table 1.3 - Ordering Information	6
Table 2.1 - USB Type "C" Receptacle Pinout.....	8
Table 2.2 - Terminal block connector pin assignment	8
Table 2.3 - DE-9P connector pin assignment	9
Table 2.4 - RJ45 connectors' pin assignment.....	9
Table 3.1 - USB Electrical Details	15
Table 3.2 - RS422/RS485 Electrical Details.....	15
Table 3.3 - Power Output Option	16
Table 5.1 - Storage Temperature.....	19
Table 5.2 - Operating Temperature	19
Table 6.1 - Import / Export Information	20

Appendix B - Revision History

Revision	Changes	Date
1.0	Initial release	03-08-2022
1.1	Updated utility Instructions (GUI & Command Line)	04-11-2022

Mouser Electronics

Authorized Distributor

Click to View Pricing, Inventory, Delivery & Lifecycle Information:

Connective Peripherals:

[USBC-H-422/485-M PRO](#) [USBC-H-422/485-M-ISO PRO](#)